

e-Manufacturing Work Shop

e-Manufacturing and APC

Koji Kitajima

TOSHIBA Semiconductor Company

Process & Manufacturing Engineering Center

Contents

- 1. What's Required**
- 2. Reformation of Manufacturing Works**
- 3. How to Realize - Architecture**
- 4. APC**

What's Required

- **Improve Manufacturing Effectiveness**
- **Coordinate Multiple Works for Manufacturing**
- **Execute Plan – Do – Check – Action Cycle of Works**
 - *Chained*
 - *Quick*
 - *Accurate*
 - *Low Cost*
- **Equipment Related Works are Big Treasures for Improvement !**



Typical Equipment Related Works

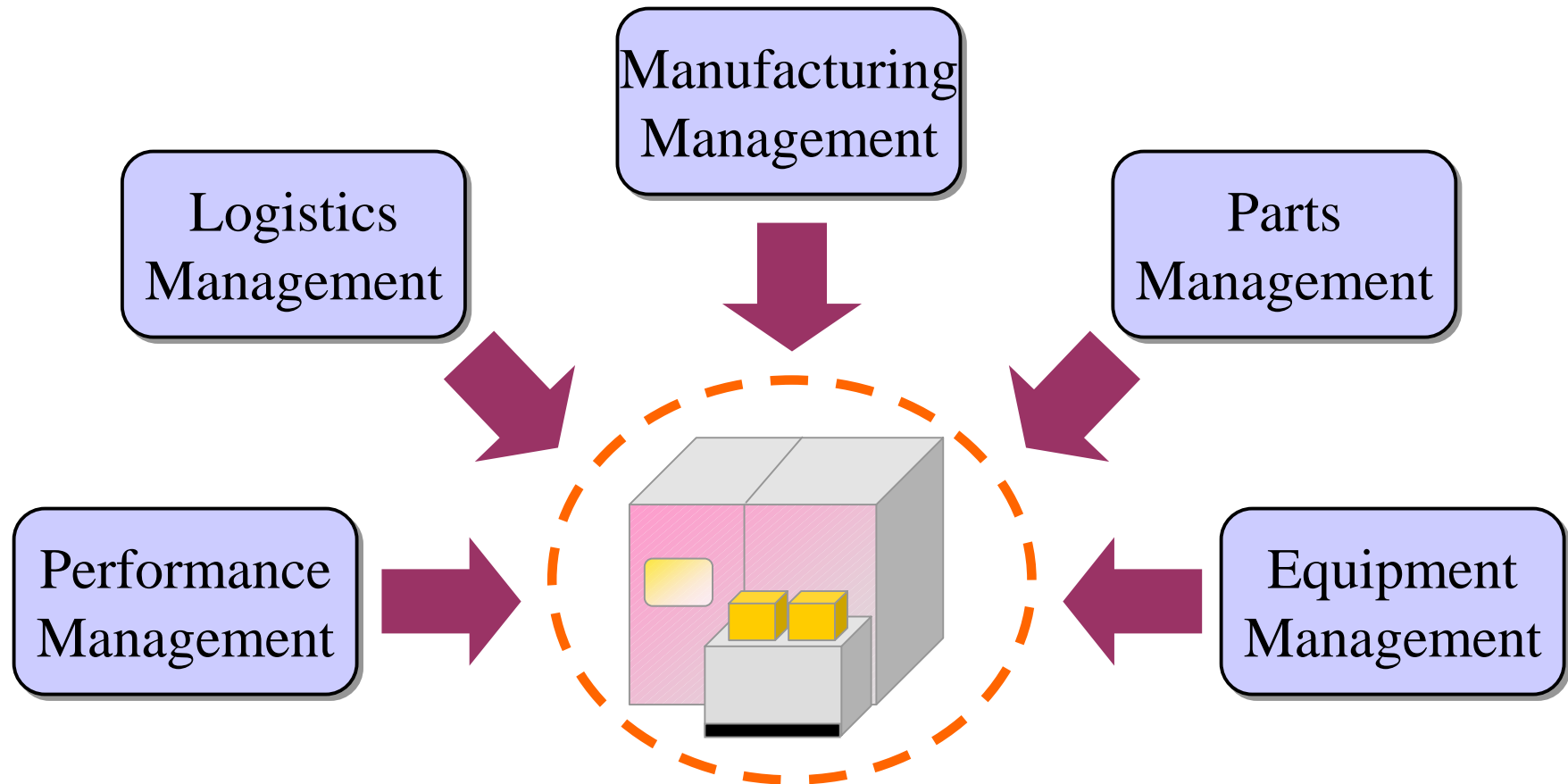

Management Cycle Chain

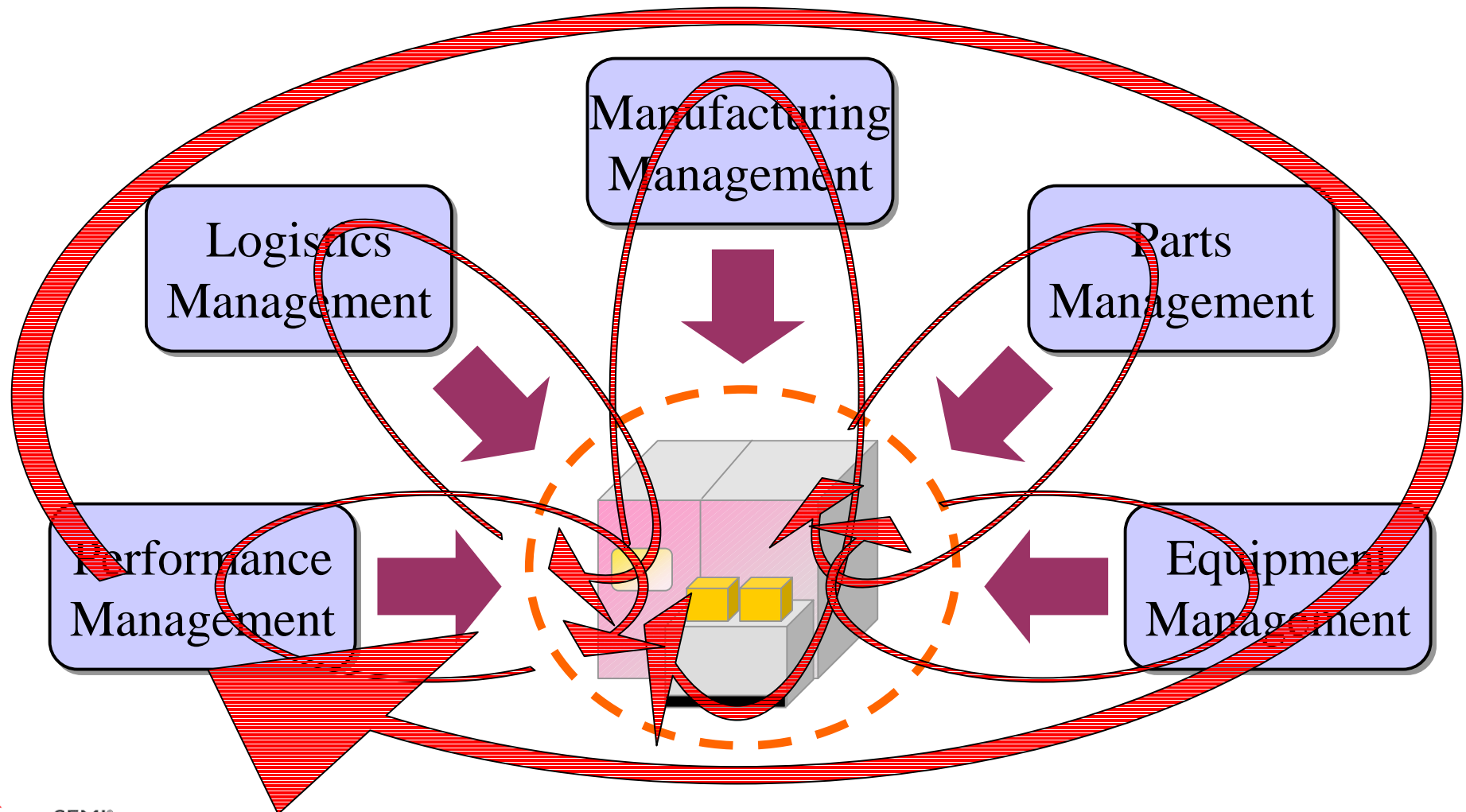

System = Execution Mechanism

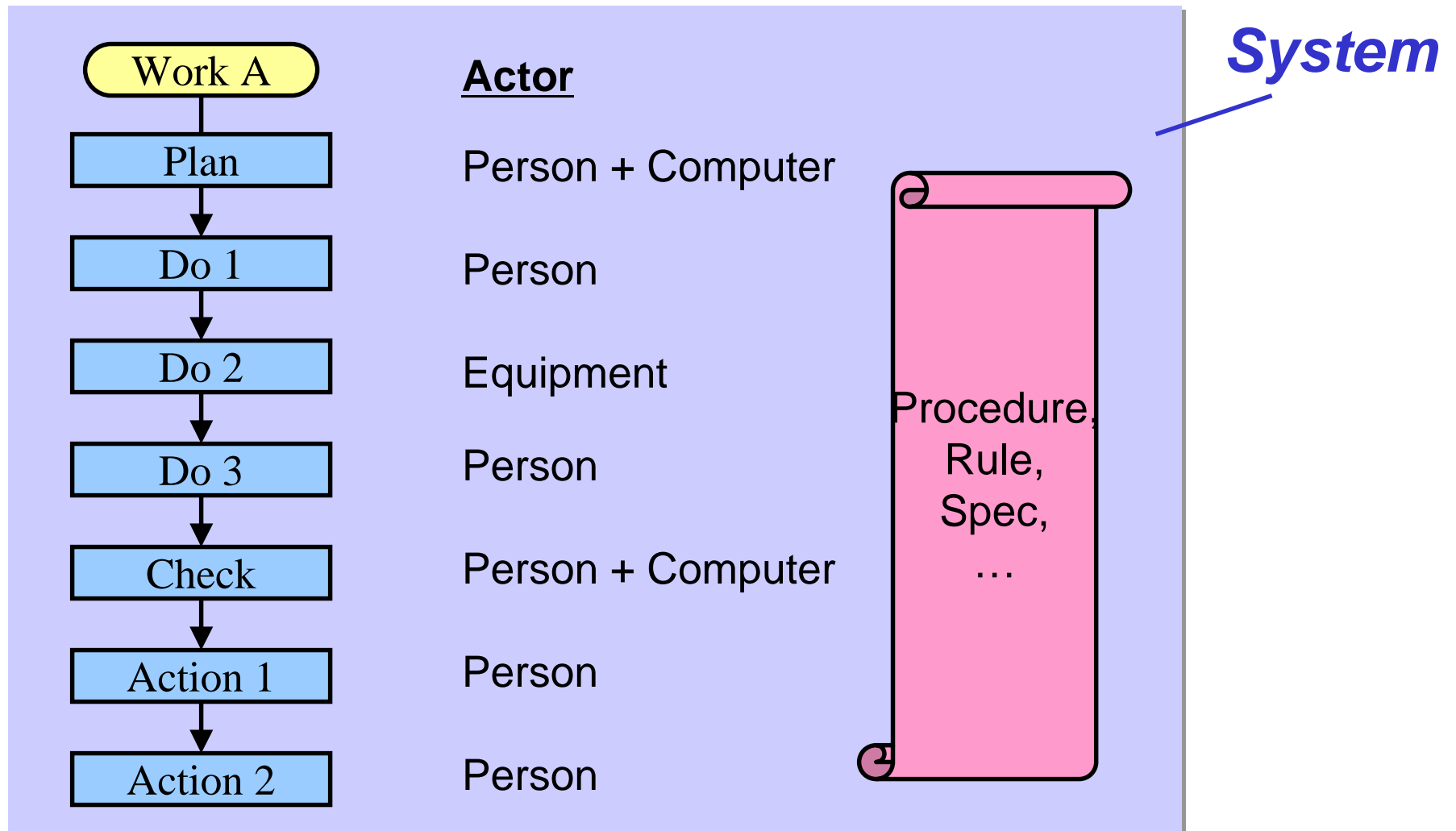

System Evolution

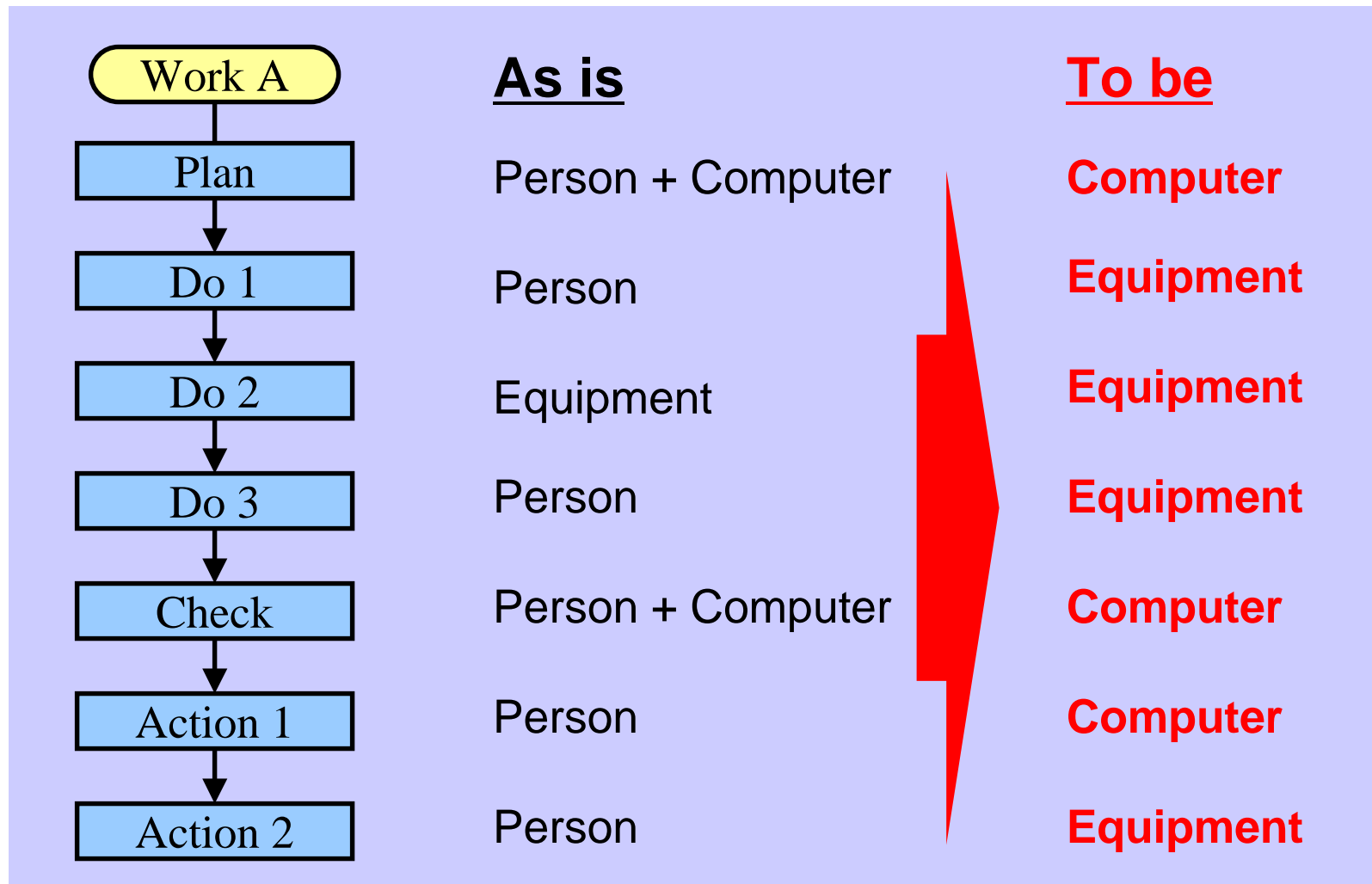

Reformation of Works with IT

- **Simplify Operations**
- **Substitute Automatic Operation for Manual Operation**
 - Person -> Equipment, Computer
- **Assist Manual Operation**
 - Guidance for Person by Computer

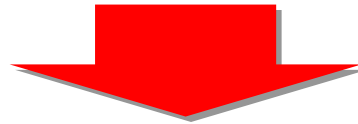

Chained, Quick, Accurate, Low Cost !



Maintenance Works

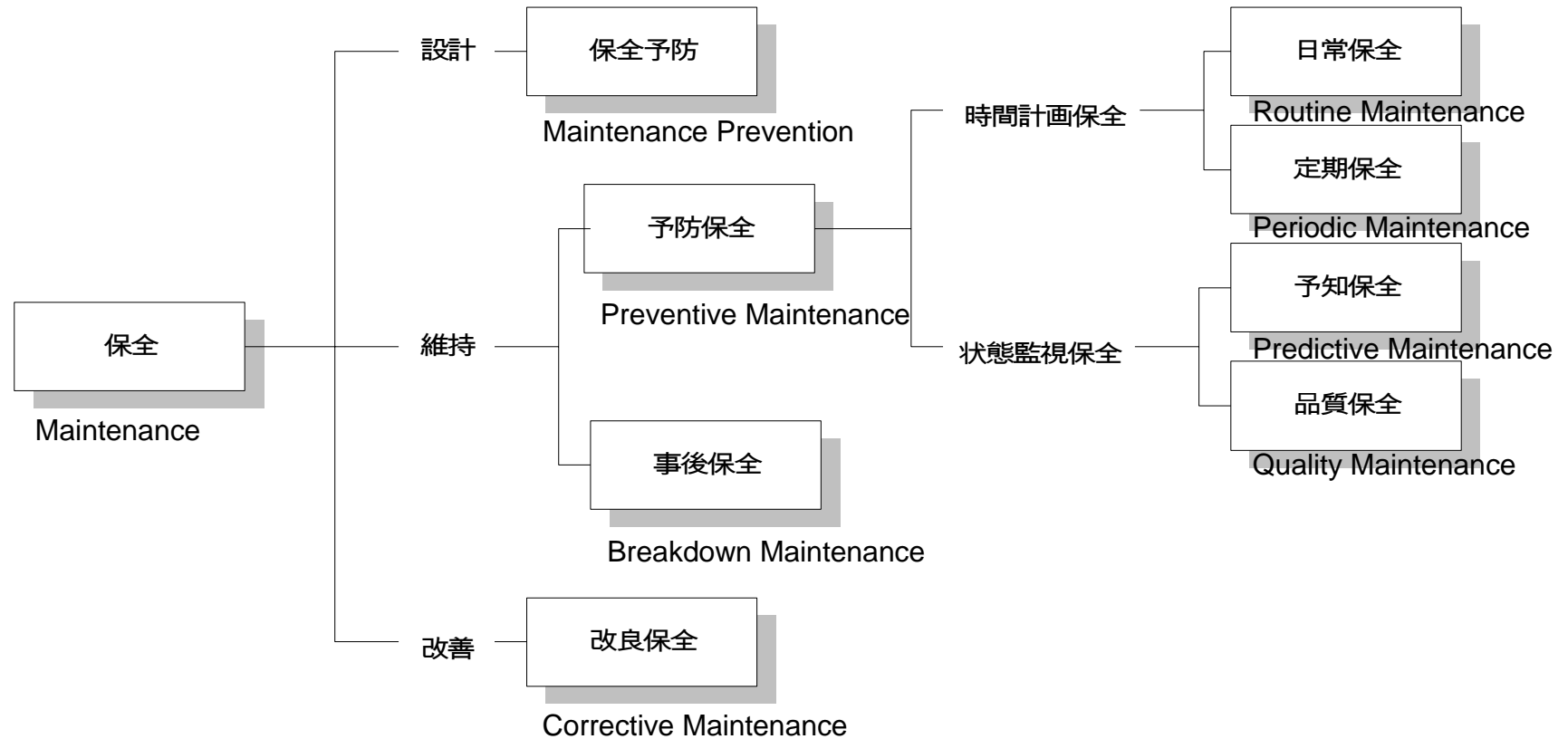

(日本生産管理学会編集 生産管理ハンドブック 日刊工業新聞社 1999 より)

Flow of a Breakdown Maintenance

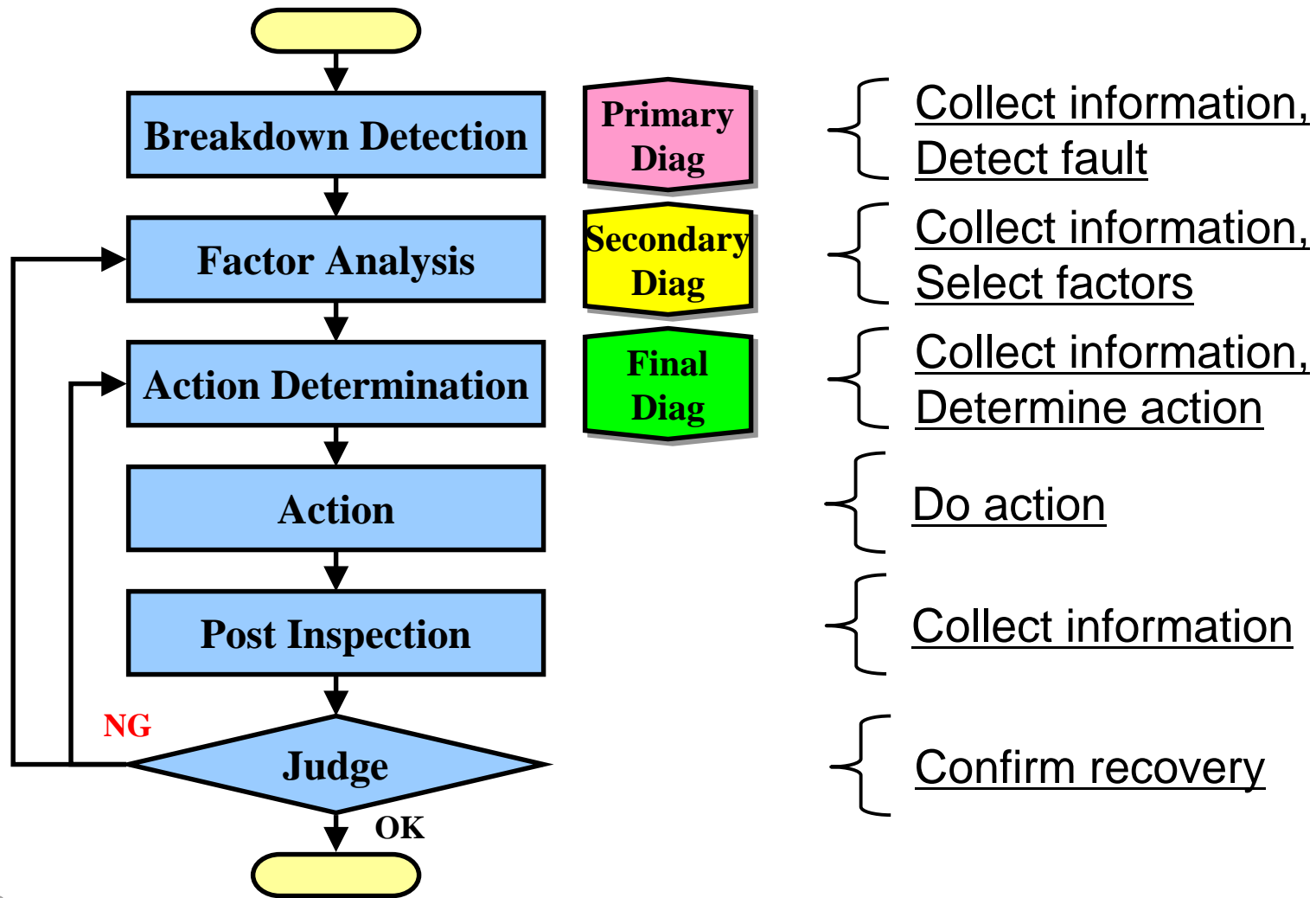

Roll Sharing on a Breakdown Maintenance

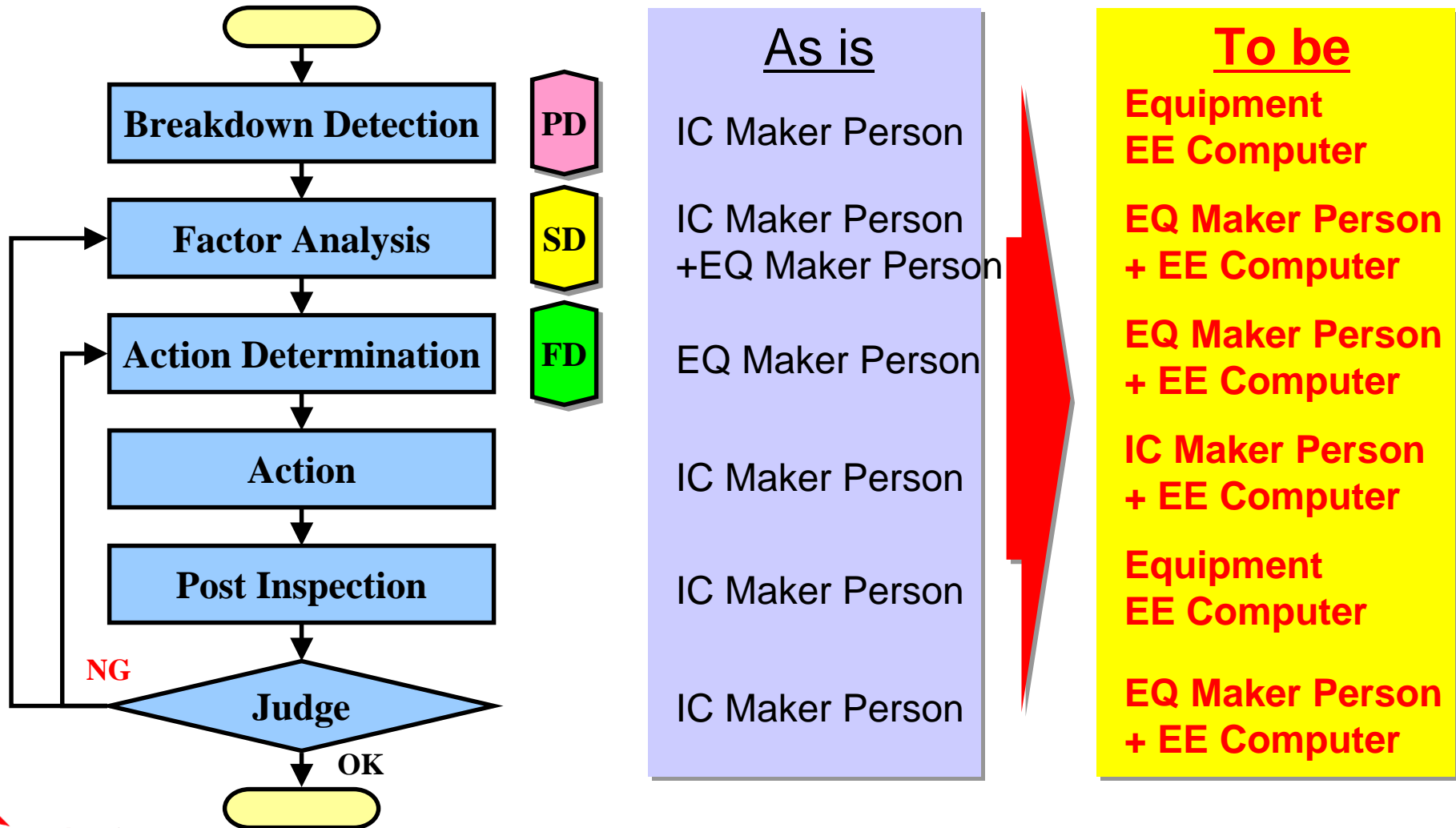

How to Realize

- **Information Sharing**
 - Sensing, Monitoring
 - Data Digitalization
 - Network
 - Security
 - Transparent Data Access
- **Application**
 - Operation Assistance, Substitution
 - Roll Sharing
- **Know How**
 - Value Addition



Information Sharing

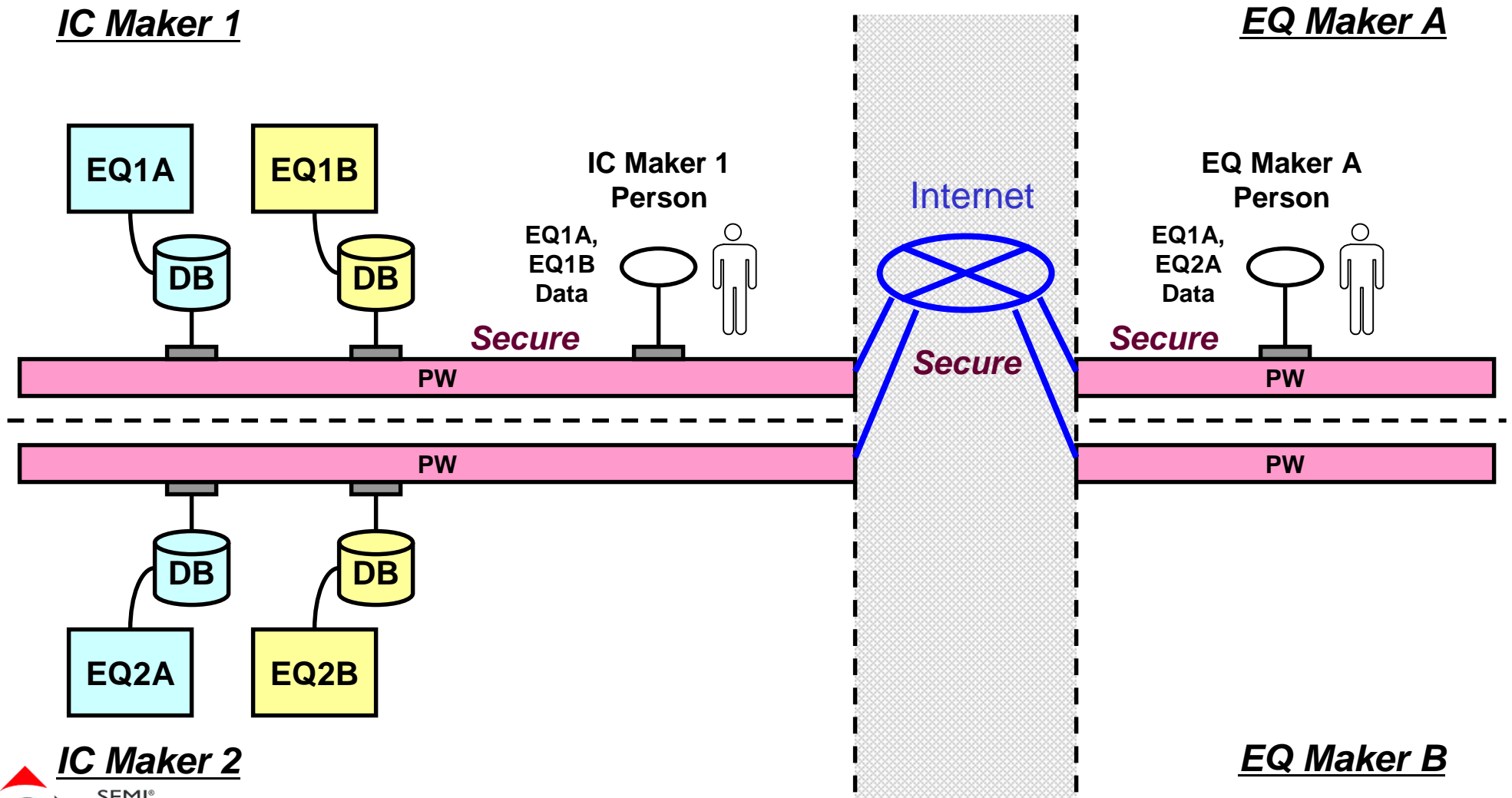

Application

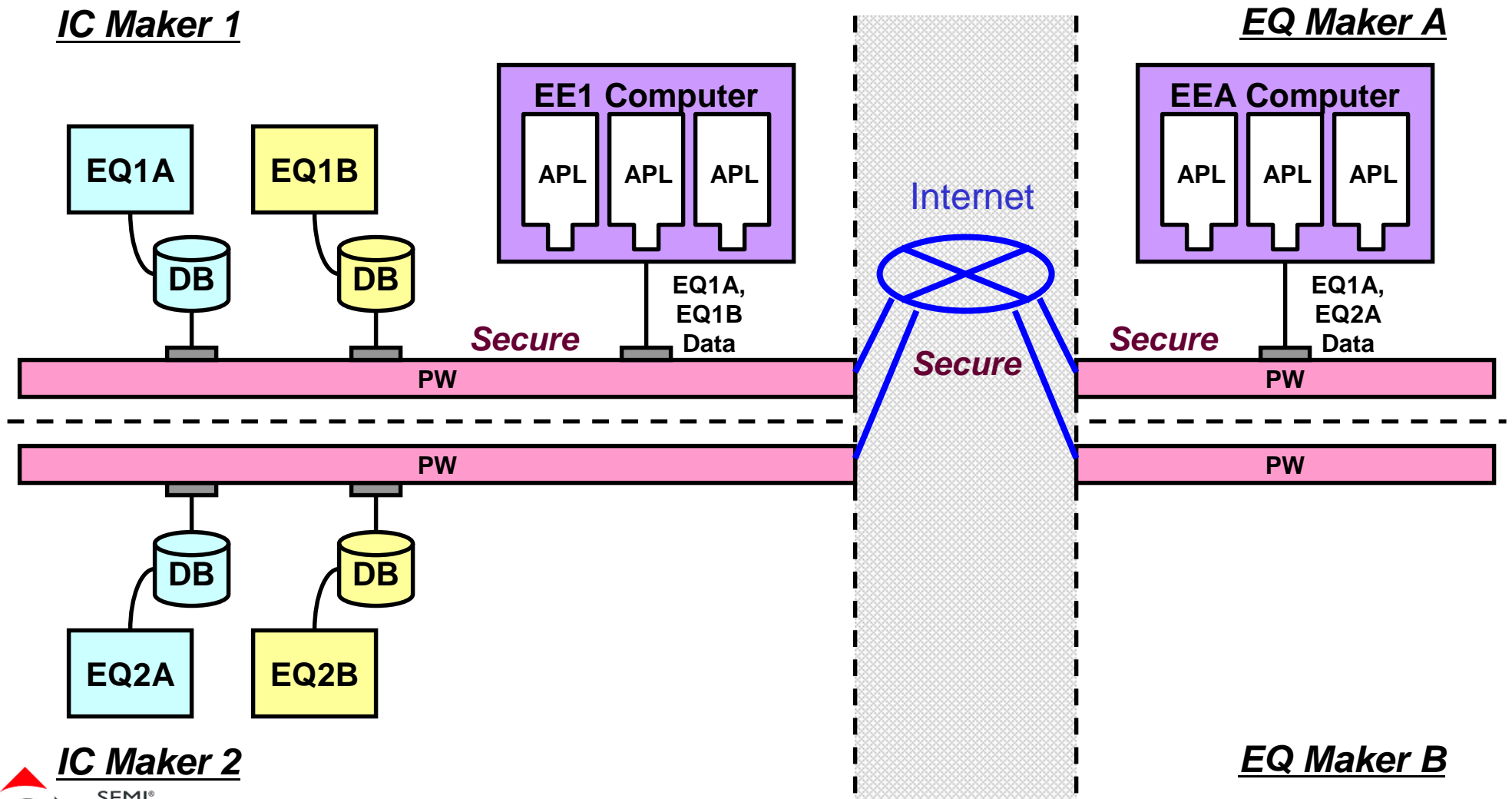

Know How

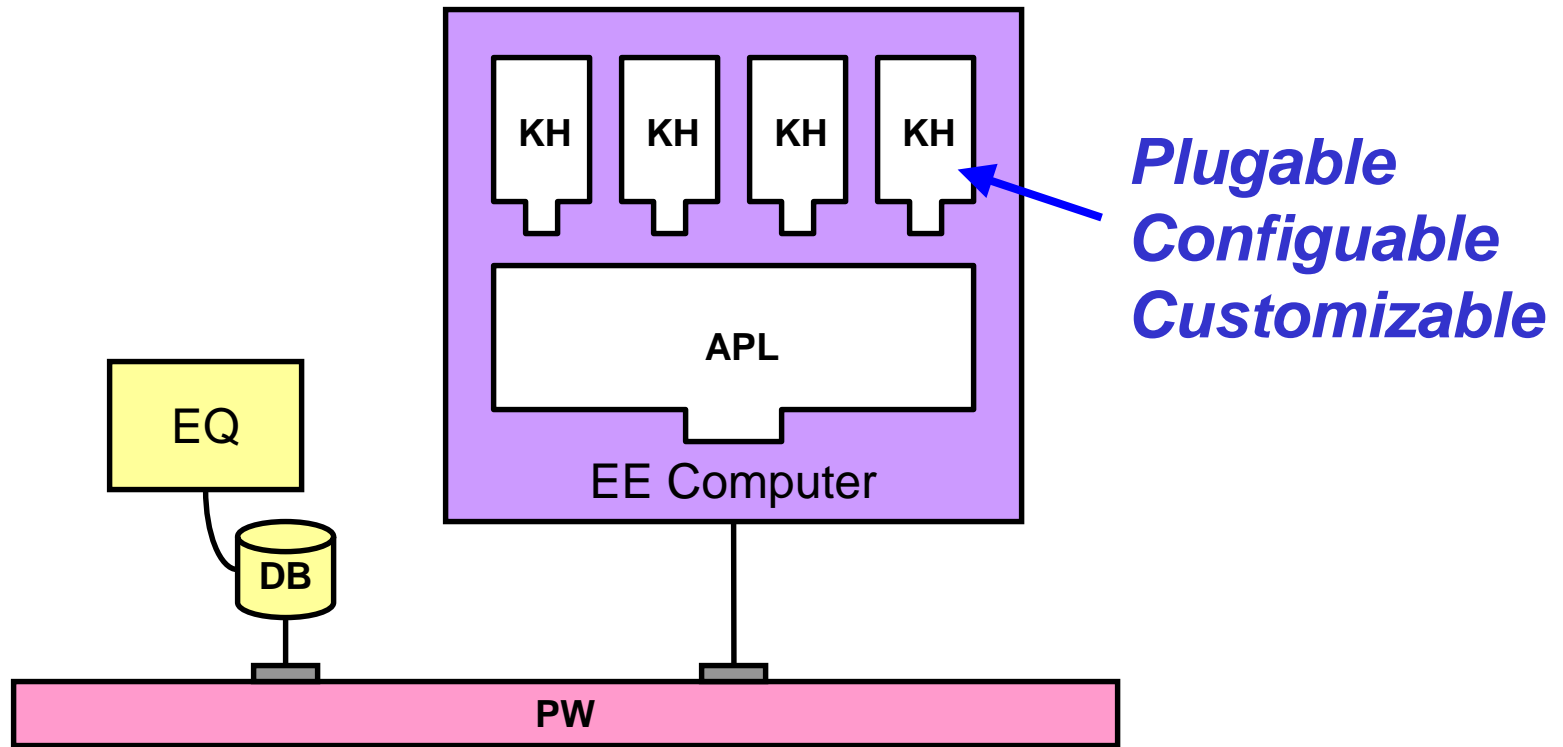

Patient and Doctor

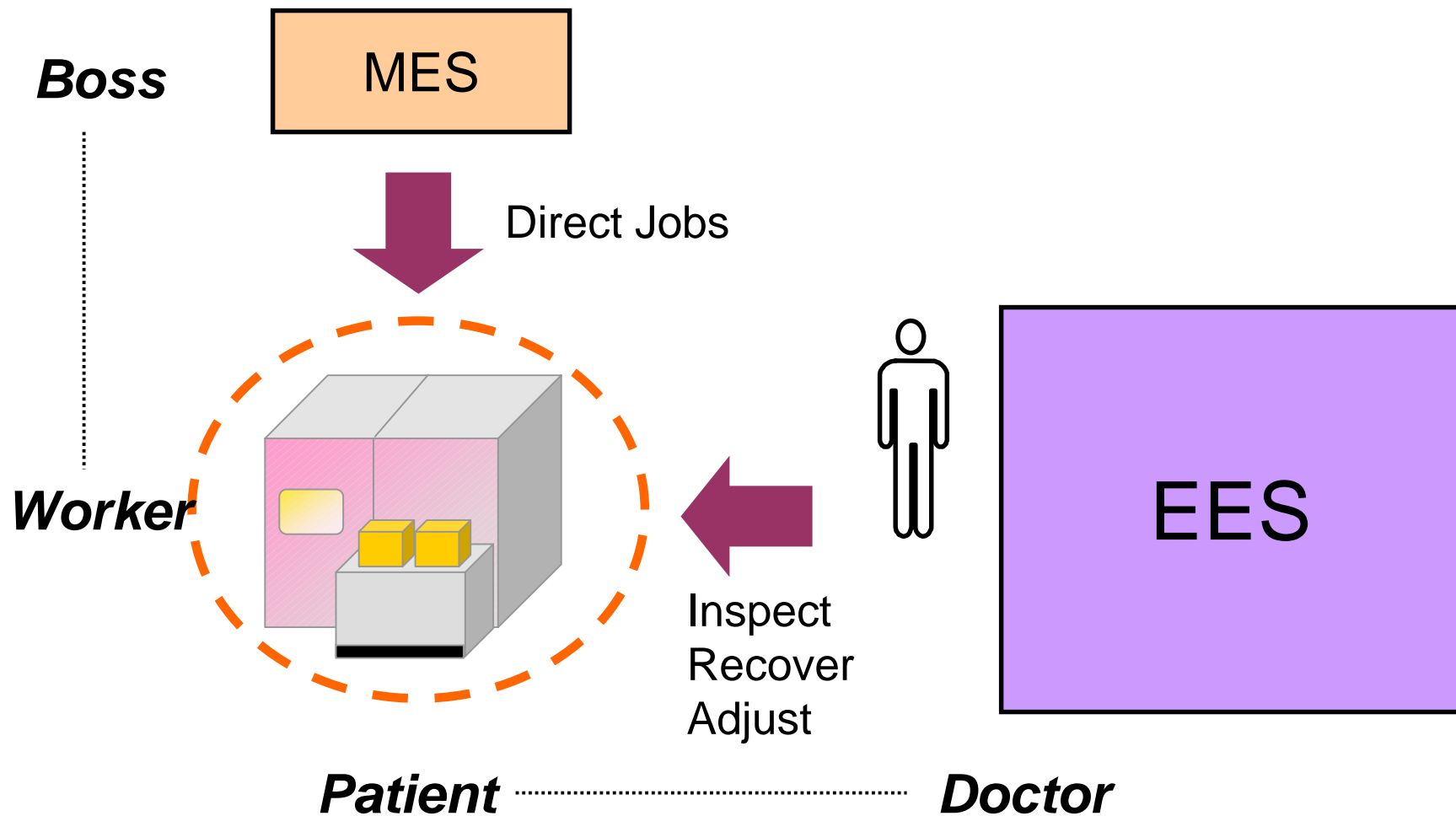

APC Capability List

- **APC**
 - **APC1 - Real Time Process Control (in-situ)**
 - **APC2 - Feed Back (R2R)**
 - **APC3 - Usage Adjustment (Equipment)**
 - **APC4 - Feed Forward (R2R)**

Typical Model of APC

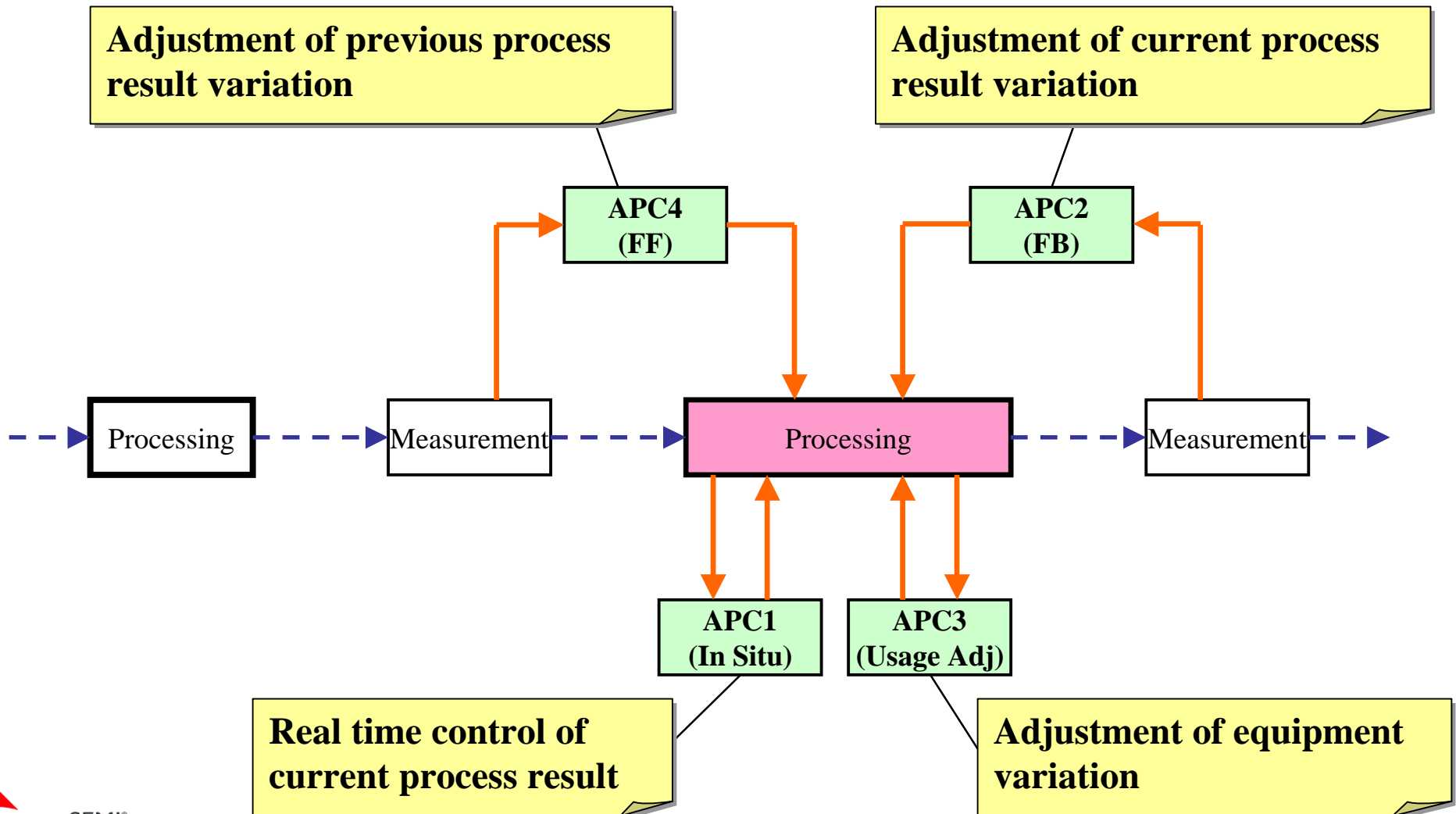

Expected Equipment Role

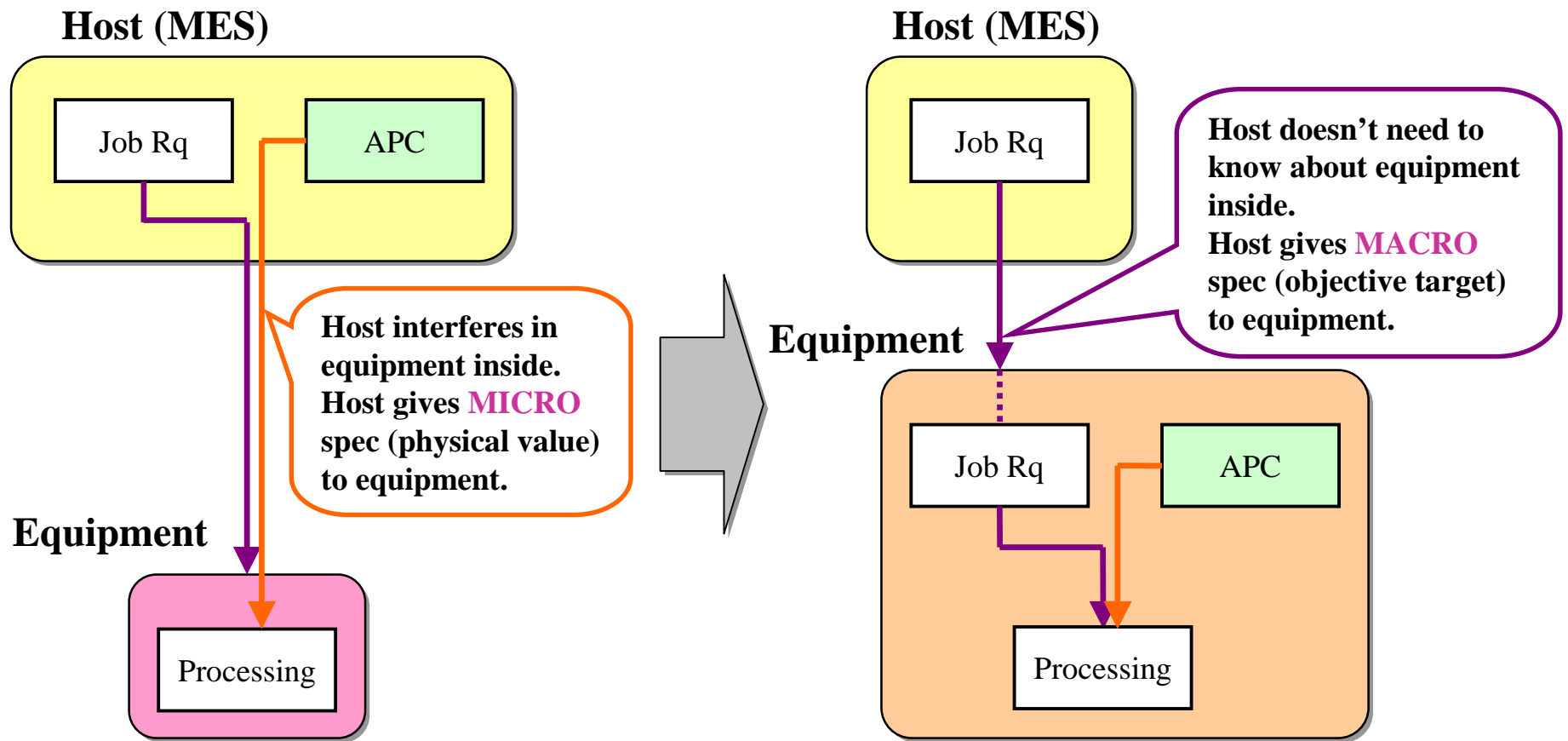

Non Autonomous Equipment

Autonomous Equipment

Basic Role Sharing between Host and Equipment

Host (MES)

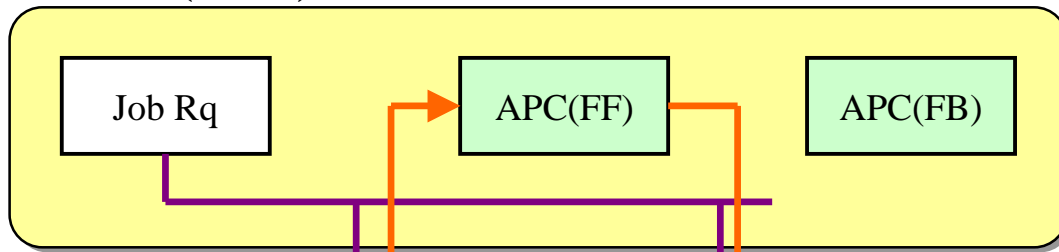

APC in Host

- Adjustment **between equipment**
- Timing control **for lot level** (Job direction to Equipment)

Equipment

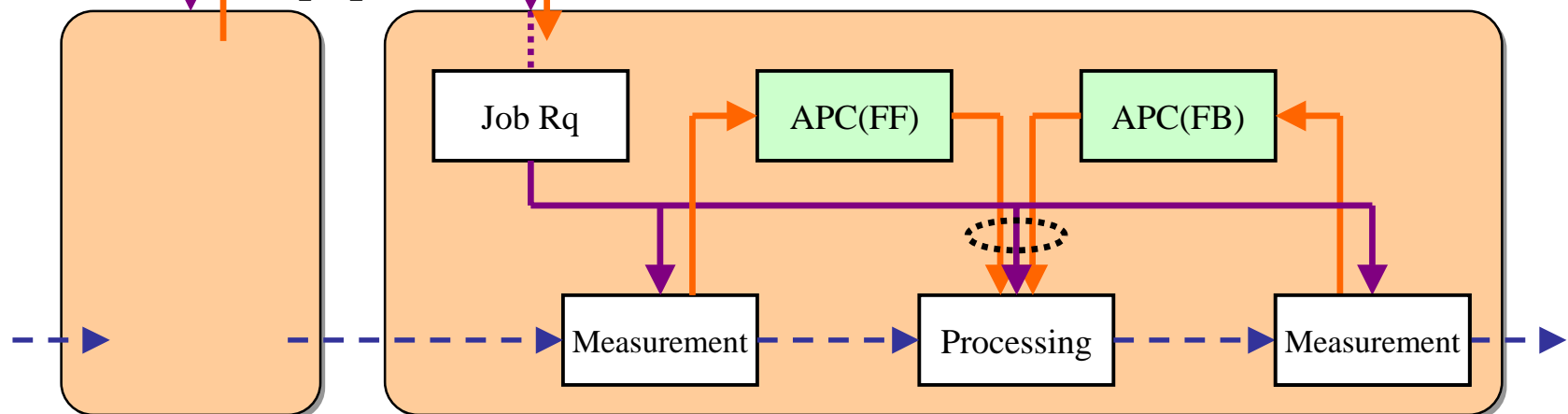

APC in Equipment

- Adjustment **inside equipment**
- Timing control **for wafer level** (Job direction to Module)

APC Mapping

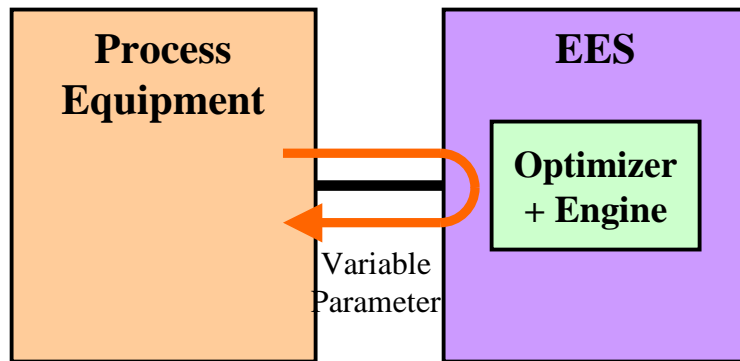
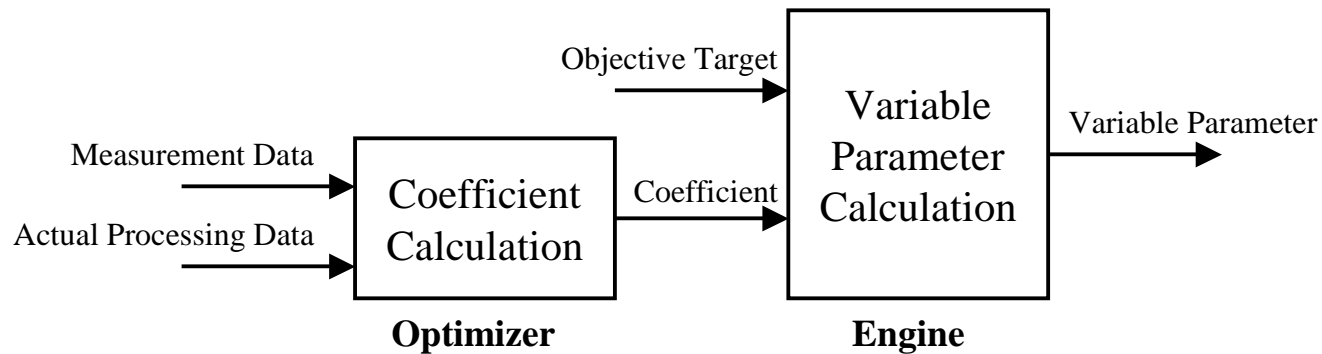

EES calculates variable parameters on demand from equipment.

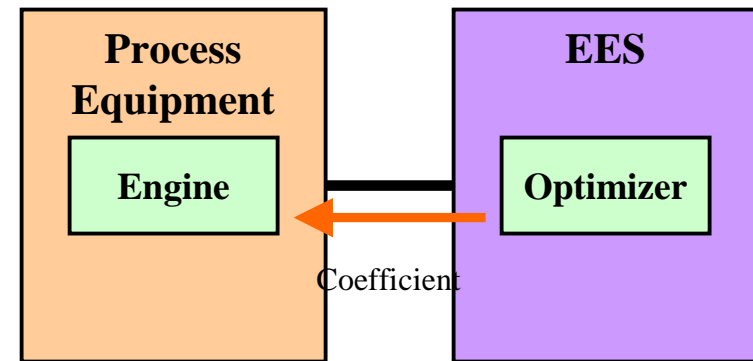

EES optimizes coefficient of equipment.

Adjustment of M2M Difference (+Drift)

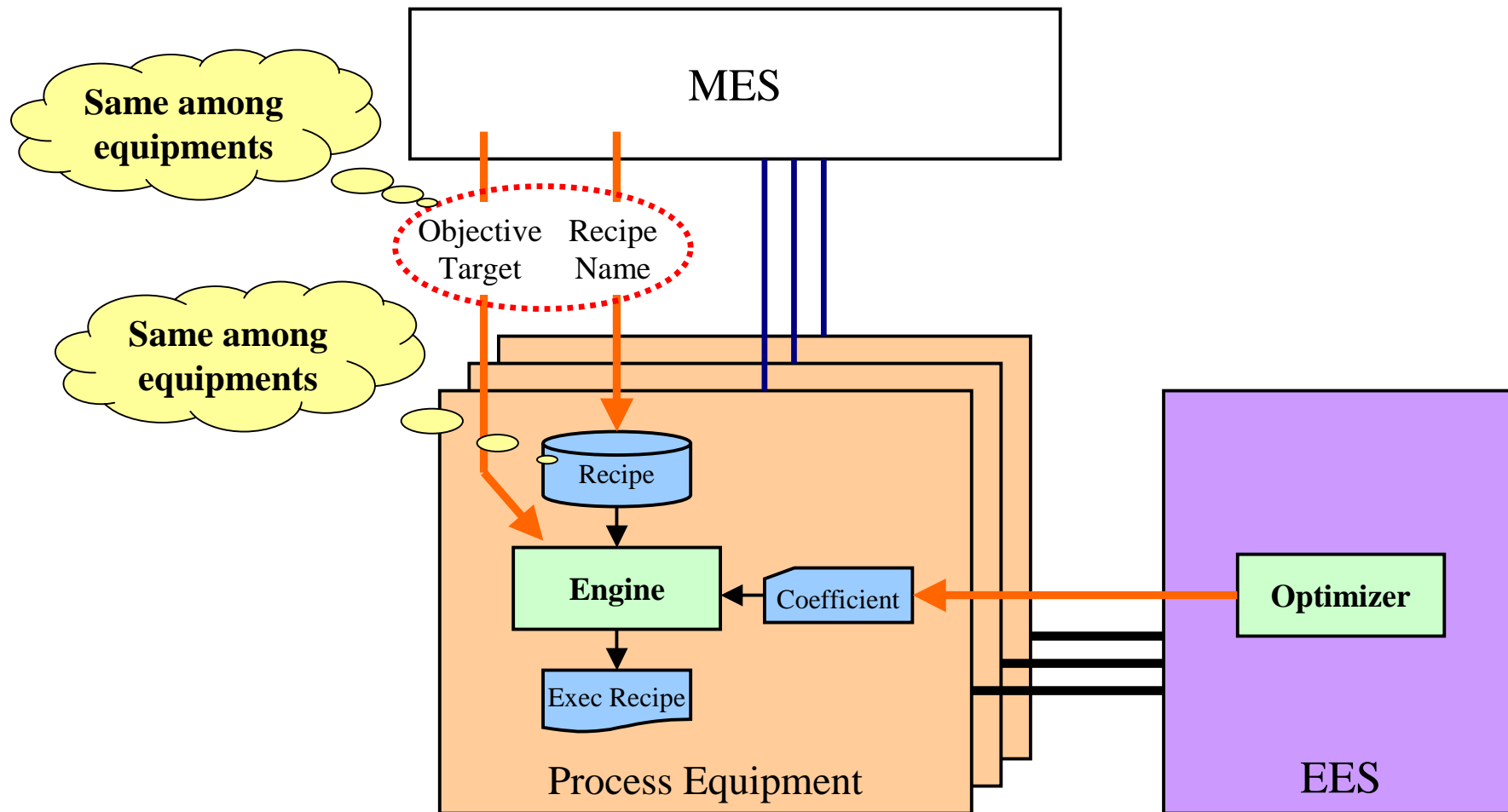

APC Architecture

- **APC Architecture**
 - Should be Platform + **Plug in**
- **Plug in**
 - Control algorithm is embedded
 - Easy to add and modify
- **Control Algorithm**
 - To be Competitive for each company
 - Assumed cases
 - Equipment maker develops and IC maker uses
 - Equipment maker develops and IC maker customizes
 - IC maker develops and uses

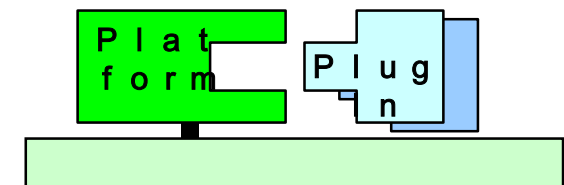

Summary

- 1. Improvement of Manufacturing Effectiveness**
- 2. Reformation of Works with IT**
- 3. New Roll Sharing, New Collaboration, New Business Model**
- 4. Basic Architecture - Data Sharing, Application, Know How**
- 5. Data Sharing and Application Framework to be Standardized**
- 6. Know How to be Competitive**