



e-Manufacturing

ST Microelectronics
Central Front end Manufacturing (CFM)

STMicroelectronics

Why e-Manufacturing ?

1 Fab

- Speed
- Manufacturing efficiency
- Business process Supply Chain
- Customer and supplier relationships

1 Equipment supplier

- Decrease equipment development and debug cost
- Better and cheaper equipment support
- Business process Supply Chain
- Flexibility



The e-Business structure for manufacturing

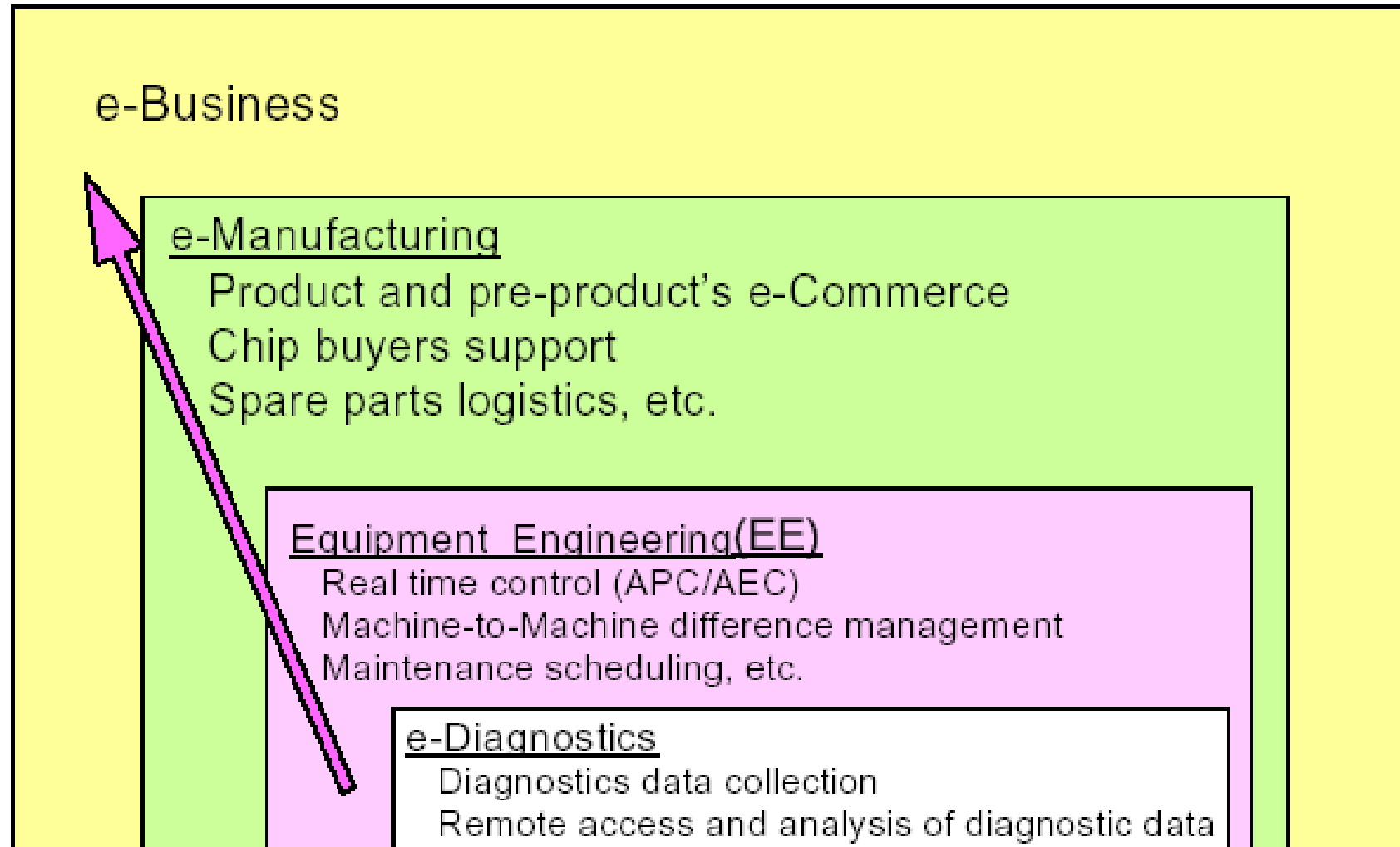

How to get there ...

- 1 Build success stories ...
- 1 Leverage experience and know-how from other industries
 - Security and connectivity
 - Data collection
 - Integration

For some companies, this requires SIGNIFICANT jumps in the learning curve to be able to profit from other industries experiences
- 1 Standards, Standards, and more STANDARDS
- 1 Clump, Chunk and Crunch: One small piece at a time



Fab

Many of the building blocks exist: the challenge is to connect the dots ...

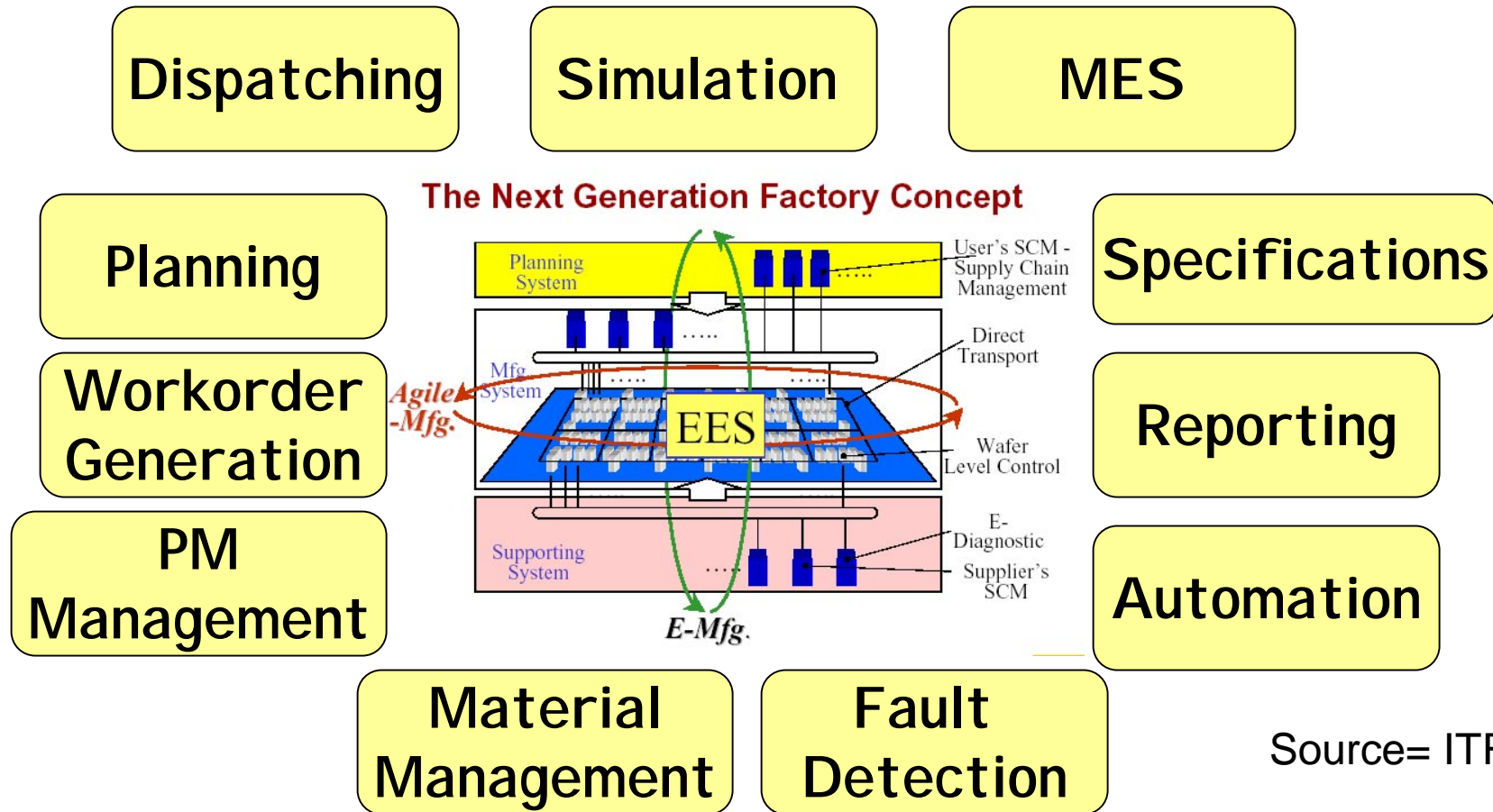

STANDARDS connect the dots



Equipment and Software Suppliers Not starting from scratch but ... Today:

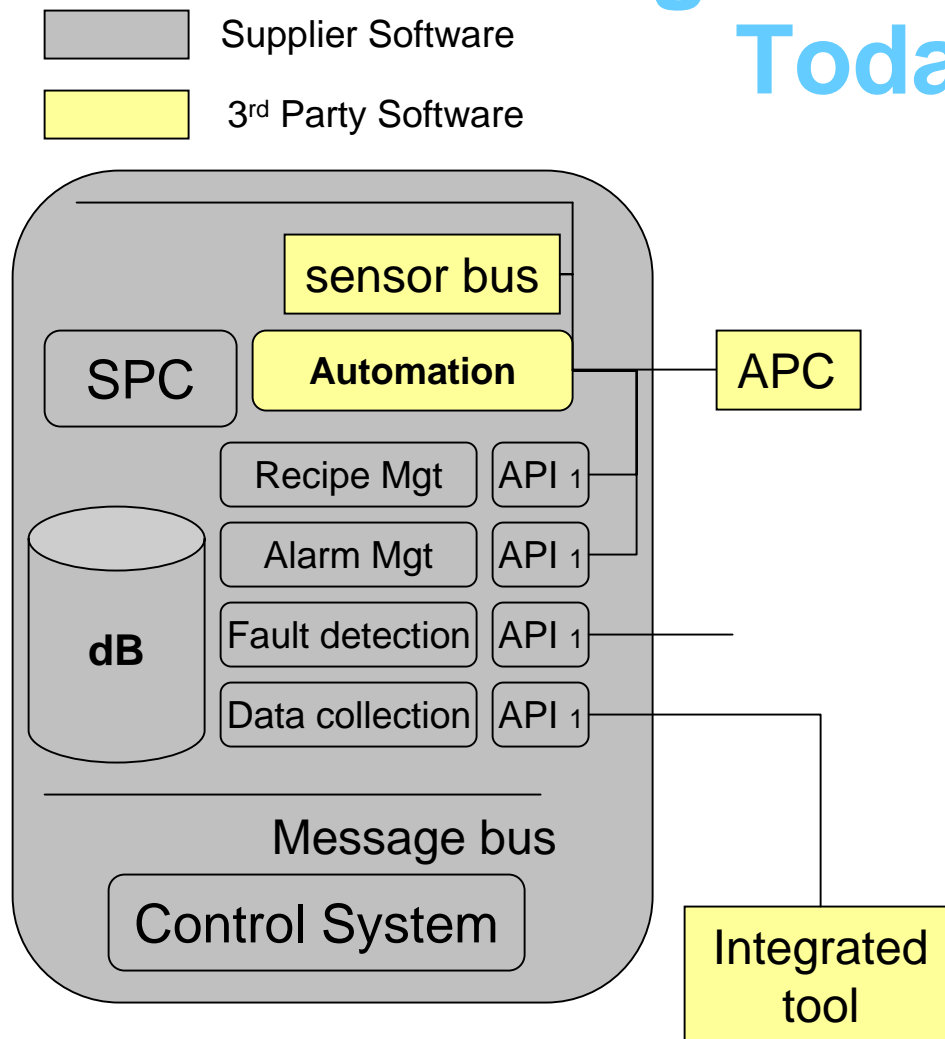

- 1 Highly software intensive
 - Many software bugs
 - High development costs
 - Long development time
 - Not so scalable
- 1 Some third party software but generally PxP integration
- 1 Hard to integrate
- 1 Complex electronic environment
- 1 Difficult to evolve
- 1 Lots of custom API-s, long to integrate and develop

Supplier and Software Suppliers

Rethink the architecture

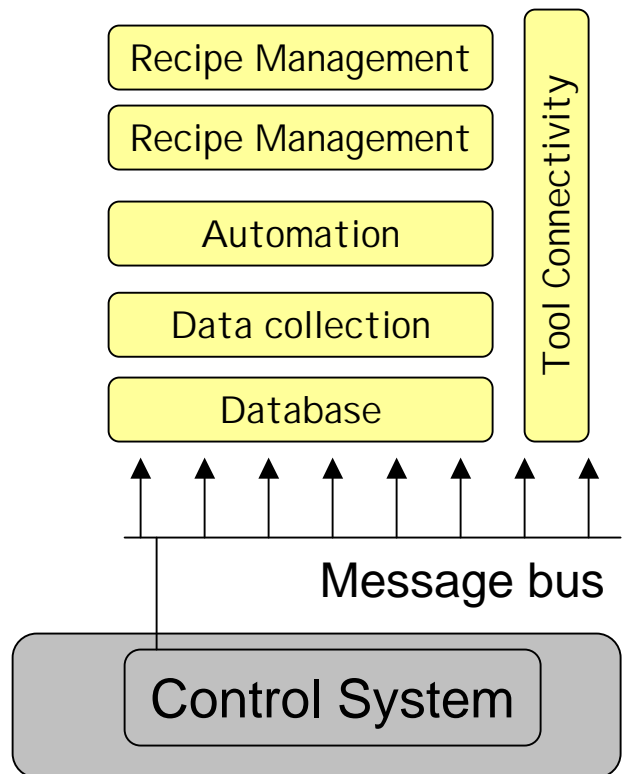

- 1 'Software' light solution
 - Faster development
 - Lower cost
 - Flexibility
 - Scalability
- 1 Open architecture plug-able to any 3rd party applications
- 1 Flexibility for supplier and customer to choose best package
- 1 Industry standard APIs
- 1 Robustness & Stability



Continued Standardization is needed to Reduce Integration Time, Cost, and Complexity

Production Equipment

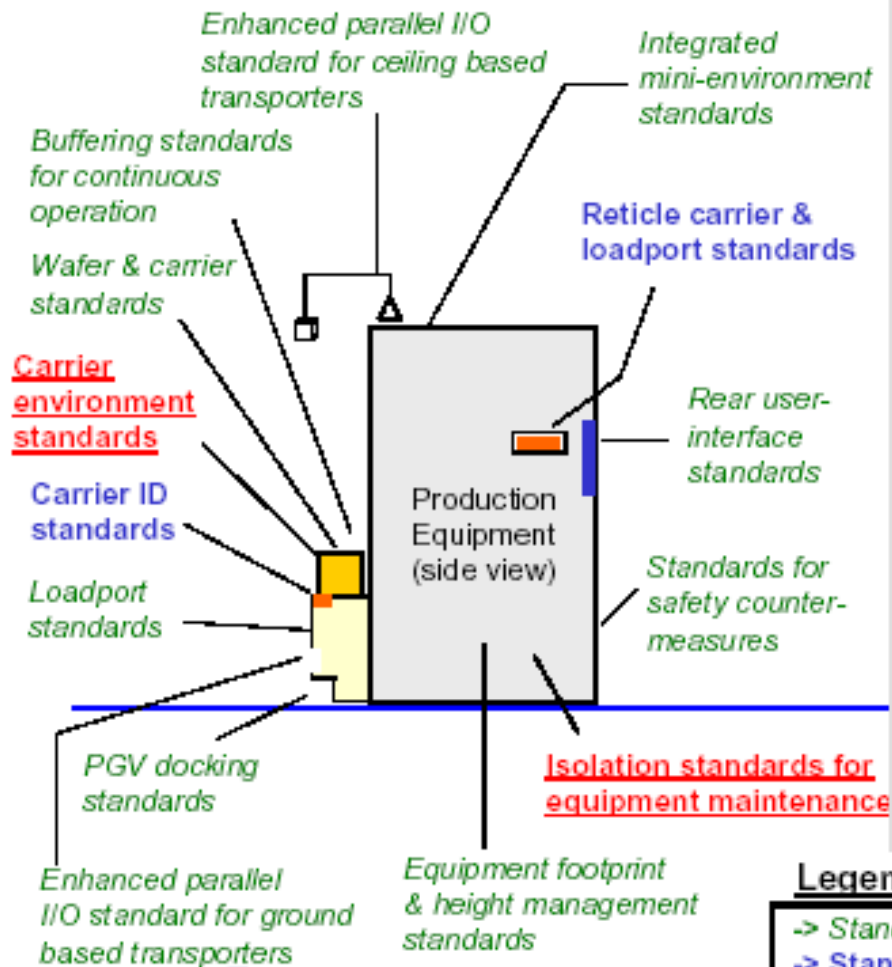

Factory Information and Control Systems

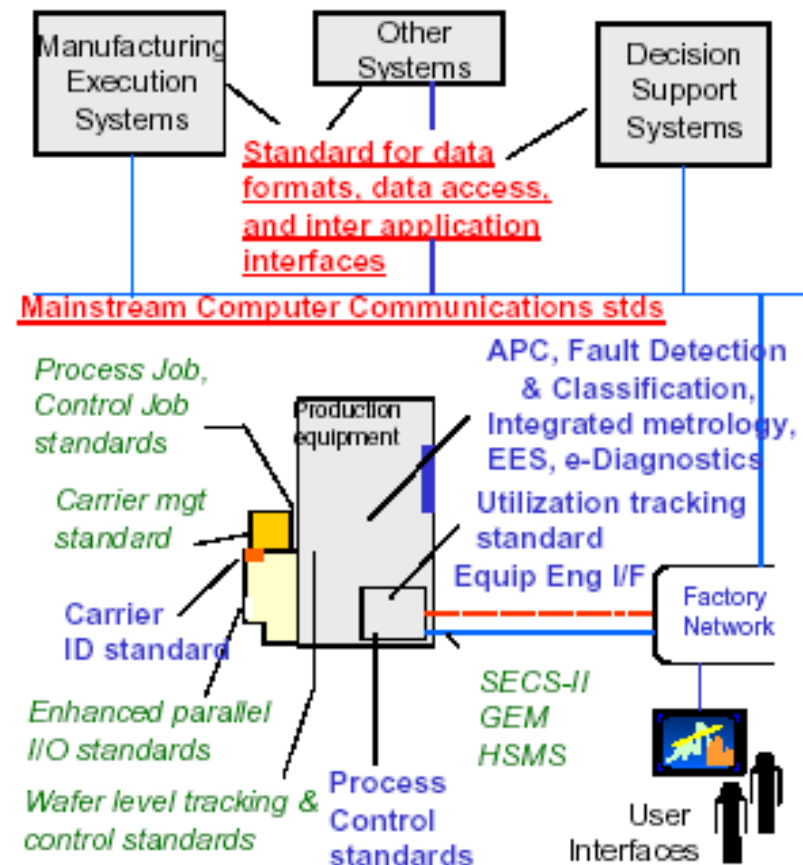

Legend:

- > Standards Exist
- > Standards Are Under Development
- > Standards Are Needed

[Back](#)

ST Focus '02 '03 Offline Information Exchange

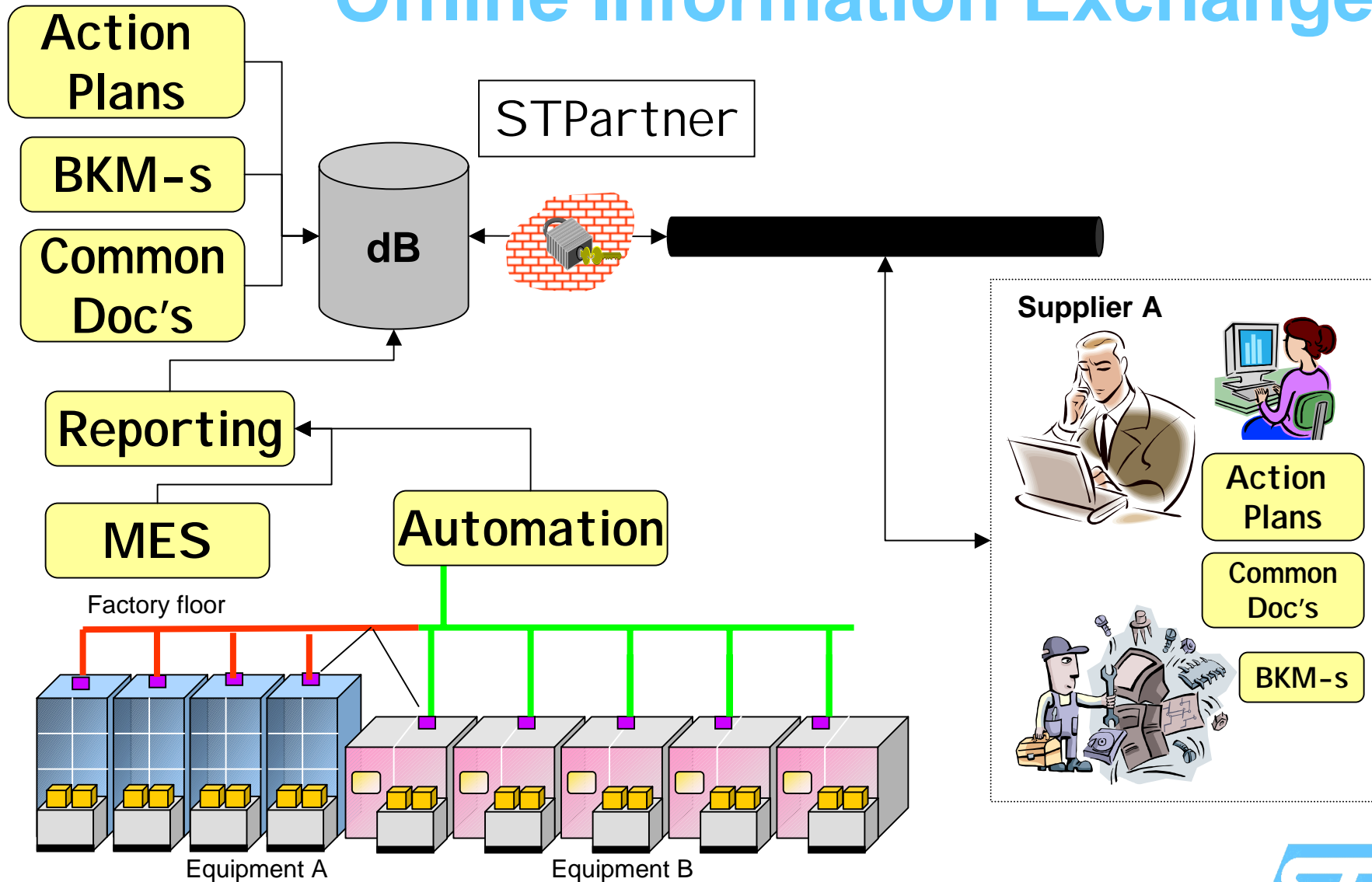



**Deploying STpartner Central
DB
to support CFM Operations**

Executive Summary

VIRTUAL CAMPUS, Technical Committee linking Operations, Suppliers and Partners

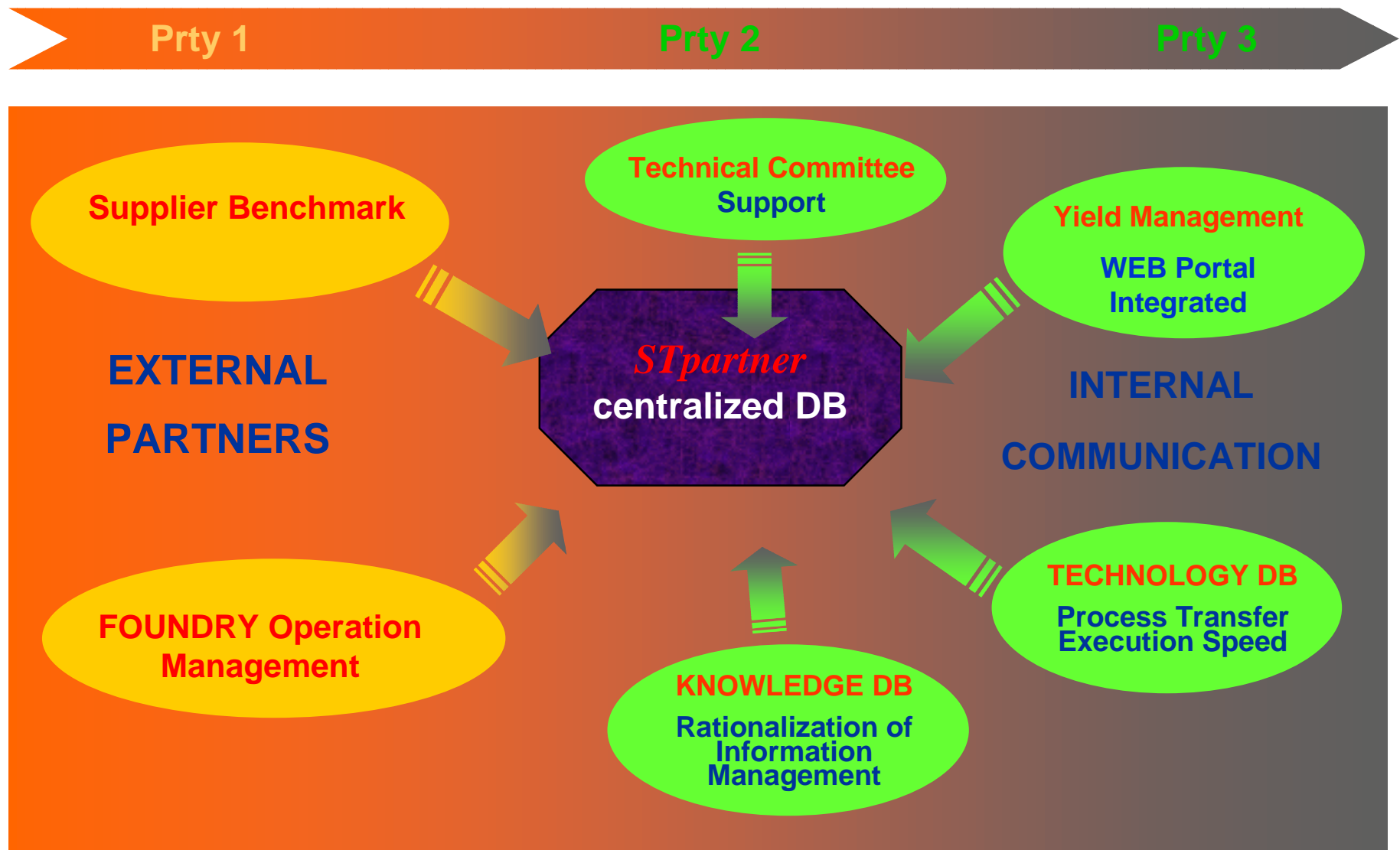

CFM Critical Programs & External Communication using ST Partner

- 1 **Supplier Benchmark** Program. Already involved: **AMAT** (Proto), **LAM**, **TEL**, **DNS**, **AXCELIS**, and **KLA**.

DB and environment for total Corporate Suppliers
Management Approach (including User Meetings)

Equipment Setting, PM and Recipe Benchmarking

Metrology Alignment, BKM & BIM Implementation and follow-up

Common Action Plan with the Supplier and Payback consolidation

- 1 **FOUNDRY Operations Management.**

STpartner is the major and the first component of the complete CCS subcontractor B2B project.

Extranet portal to exchange sensitive information
between ST and foundries.

Provide visibility to Divisions on ST “Virtual Fabs”



Other Critical CFM programs using STpartner

1 **YIELD MANAGEMENT STEERING COMMITTEE**

1. **Technical Committee Support**

Support Technical Committee Approach foundry like for management of key technical areas at company level. Should include migration of some key OLC's.

2. **Integrated Portal Approach for YIELD Management**

Develop a WEB integrated portal approach to manage yield issues first with further application to other key programs

1 Quick yield alert, comparative reports, Cycle-Time, Scrap and Cost Reduction Activities etc.

1 **KNOWLEDGE DB - Rationalization of Information Management**

Provide an integrated platform for easy retrieving of key internal information related to process manufacturing.

1 **TECHNOLOGY DB**

Upload Sensitive documents about a technology/product since 1st industrialization, then extend the access to the Receiving Plant

EQUIPMENT REPORTING

Share alarms, Reliability, Availability, and Productivity Data with the supplier



Backup slides



e-Manufacturing Hierarchy

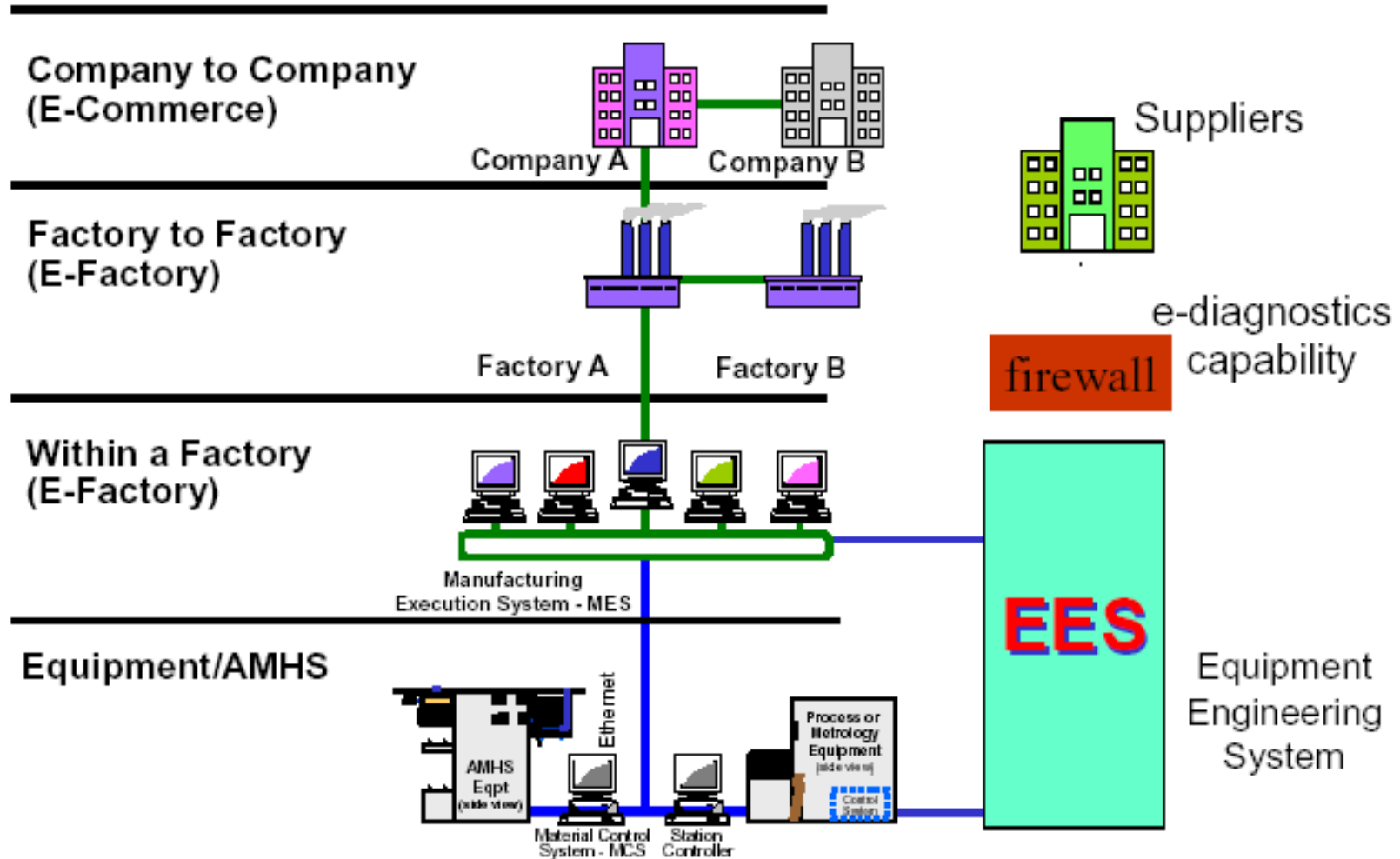

E-manufacturing Direction

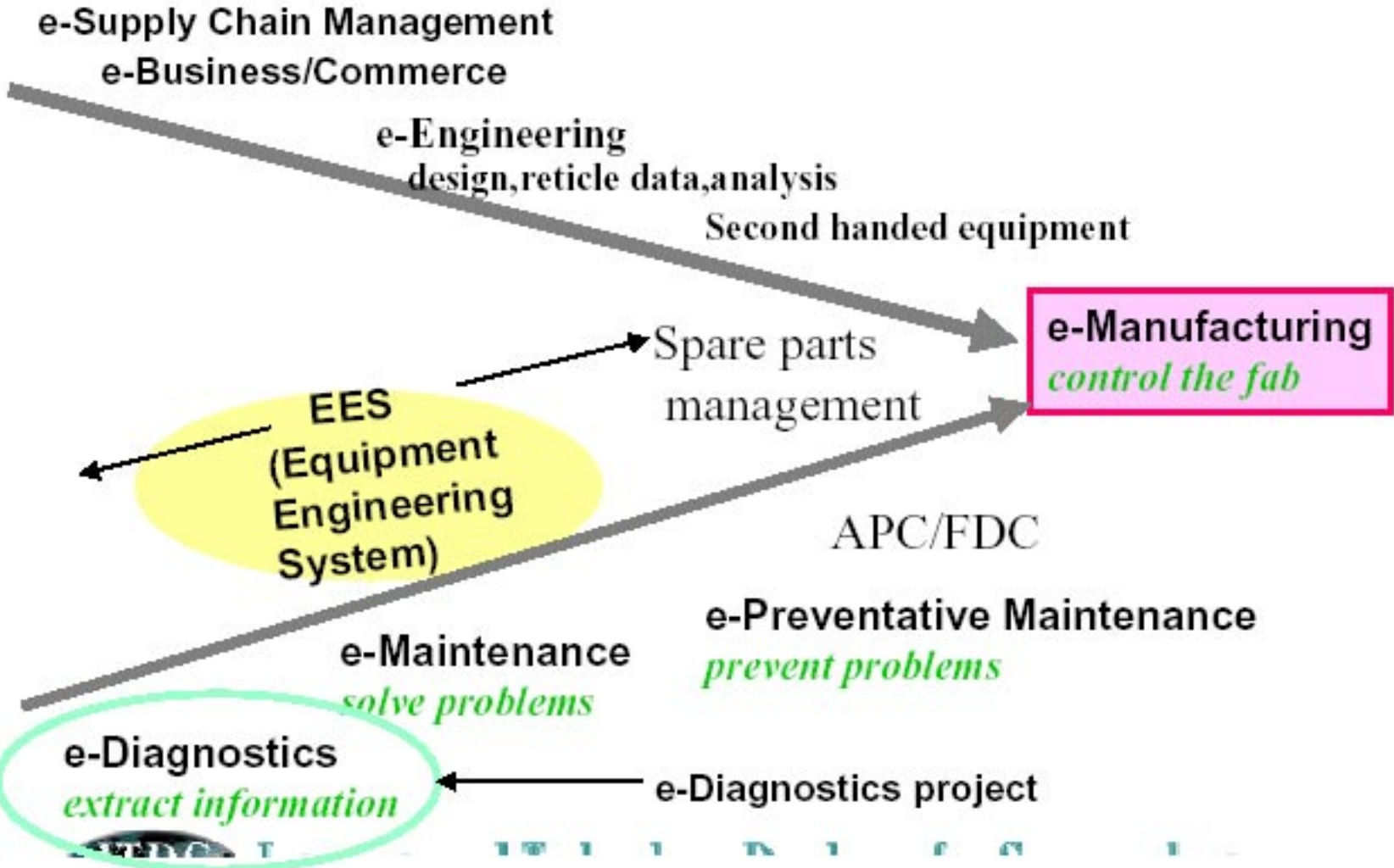

What will Equipment Engineering Systems (EES) replace?

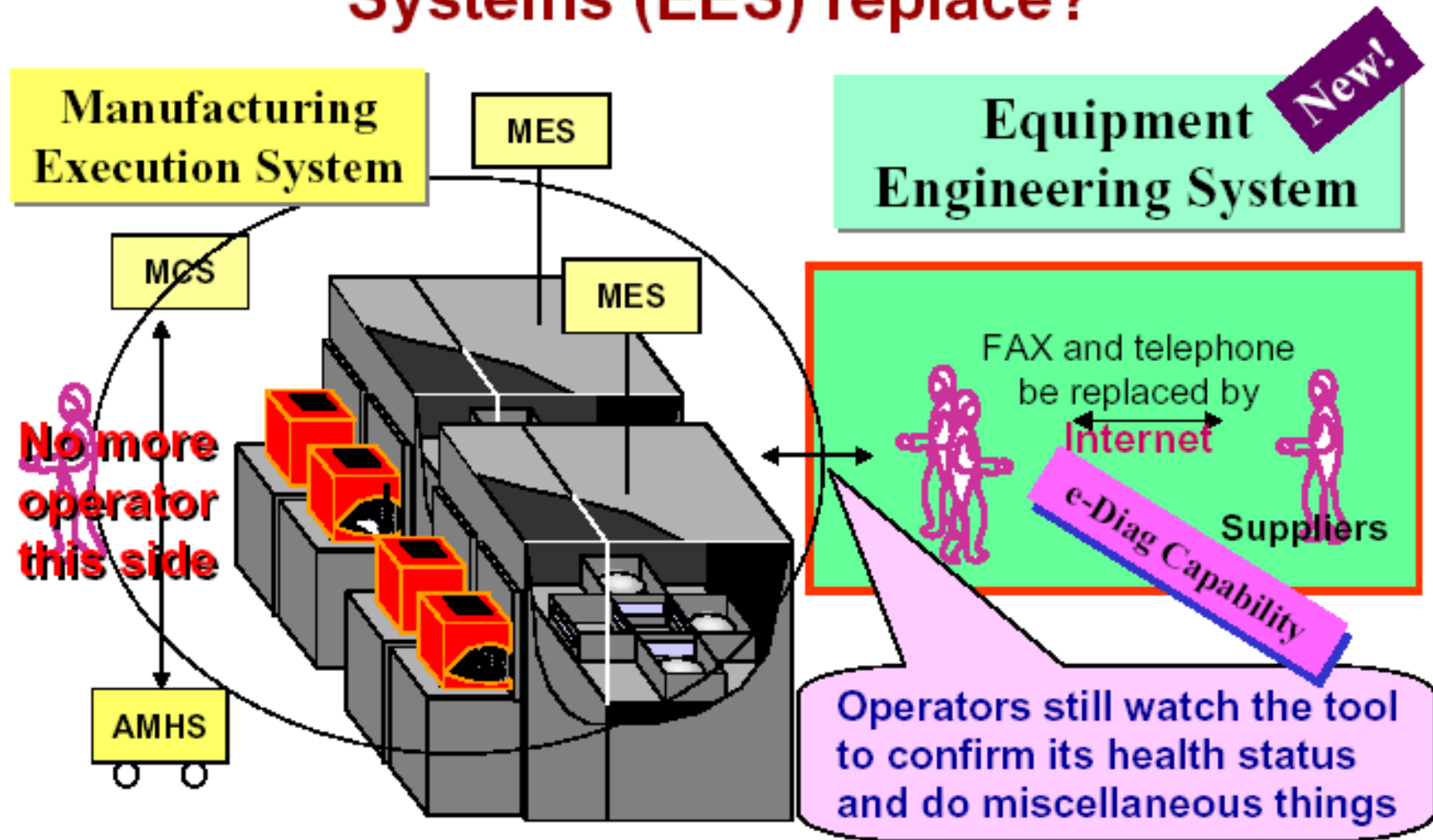

ITRS and Adv. Process Control

ITRS Process Control discussion is divided into 3 basic high level Capabilities

- 1 Fault Detection and Classification
 - ITRS Problem: Prevent scrap or equipment damage
- 2 Run to Run Control (lot to lot, and wafer to wafer)
 - ITRS Problem: Optimize performance to processing spec
- 3 Integrated Metrology
 - ITRS Problem: Reduce module level TPT + AMHS moves

Fault Detection and Classification

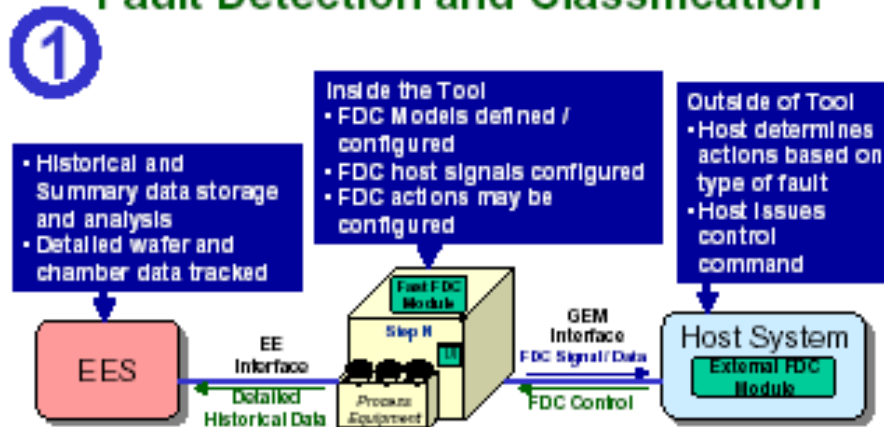

2 Run to Run Control

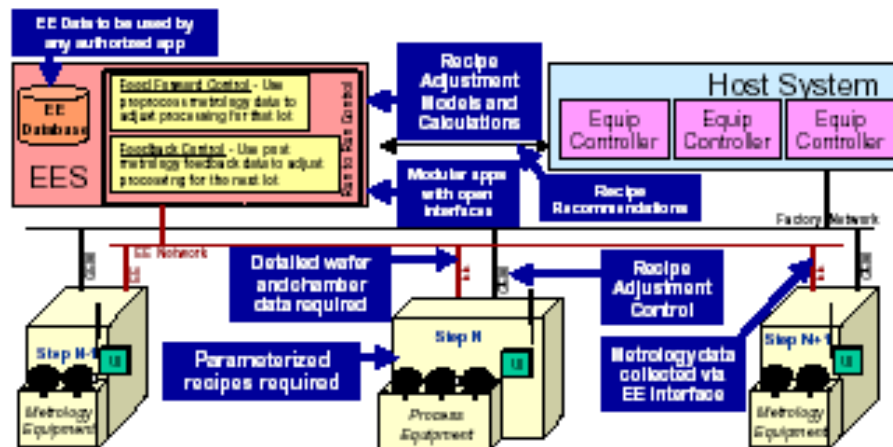

3 Integrated Metrology

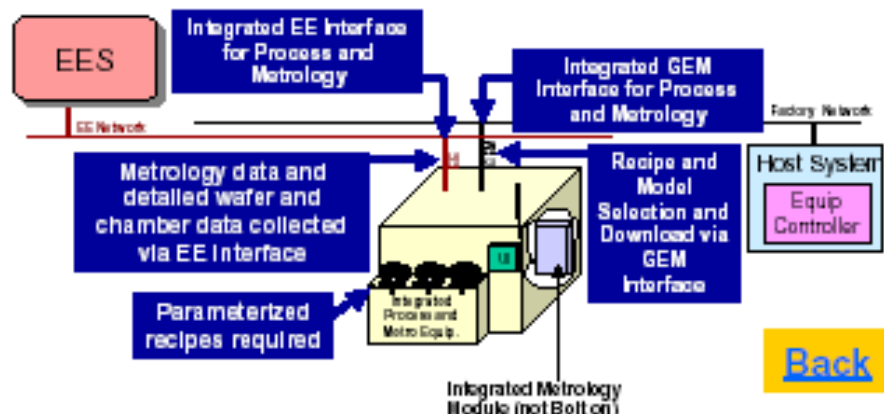

Internal Users Feed-back on STpartner

⌚ **Enthusiastic:** the system is considered “VITAL” to support Corporate Working Group approach

┆ The connections to the prototype at the moment are equivalent to **30 (thirty)** OLC's



┆ After only 2 months and at prototype stage traffic is already **~30% of the total traffic** on S

┆ More than **80** documents already inside

┆ Used all over the Company

┆ **> 500** connections per week from both side

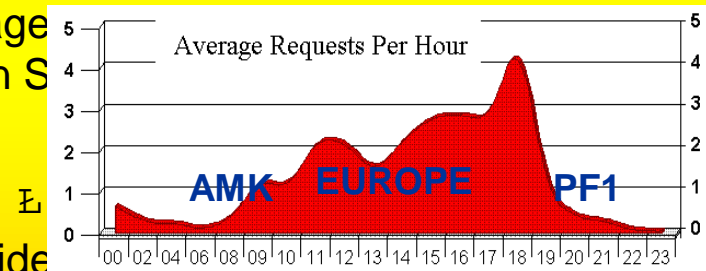

⌚ **VIRTUAL CAMPUS** concept fully acknowledged at Process Engineering level and now at Equipment Engineering level as well

Great: R2 started on volunteer basis, connections are continuously increasing



Spontaneous requests from Crolles to access the system

Meeting on wk09 to get Crolles acknowledgement for the Program and the tools



Users Feed-back on STpartner: suppliers



⌚ Enthusiastic support: more than 50% of uploaded document for Process Benchmarking were from them

⌚ Pro-active discussion for the site development (add resources, discussion lines, deepen the partnership)

⌚ Benchmarking STpartner for deployment of AMAT e-business web



⌚ Good support and feedback. System seen as a Milestone for partnership



⌚ Strongly committed to have access to the site



⌚ Pushing to have access to the site

⌚ Ready to migrate their old-fashioned DNS Info-System approach to STpartner for sensitive information fan-out



⌚ Pushing to have access to the site



STpartner for foundries: overview

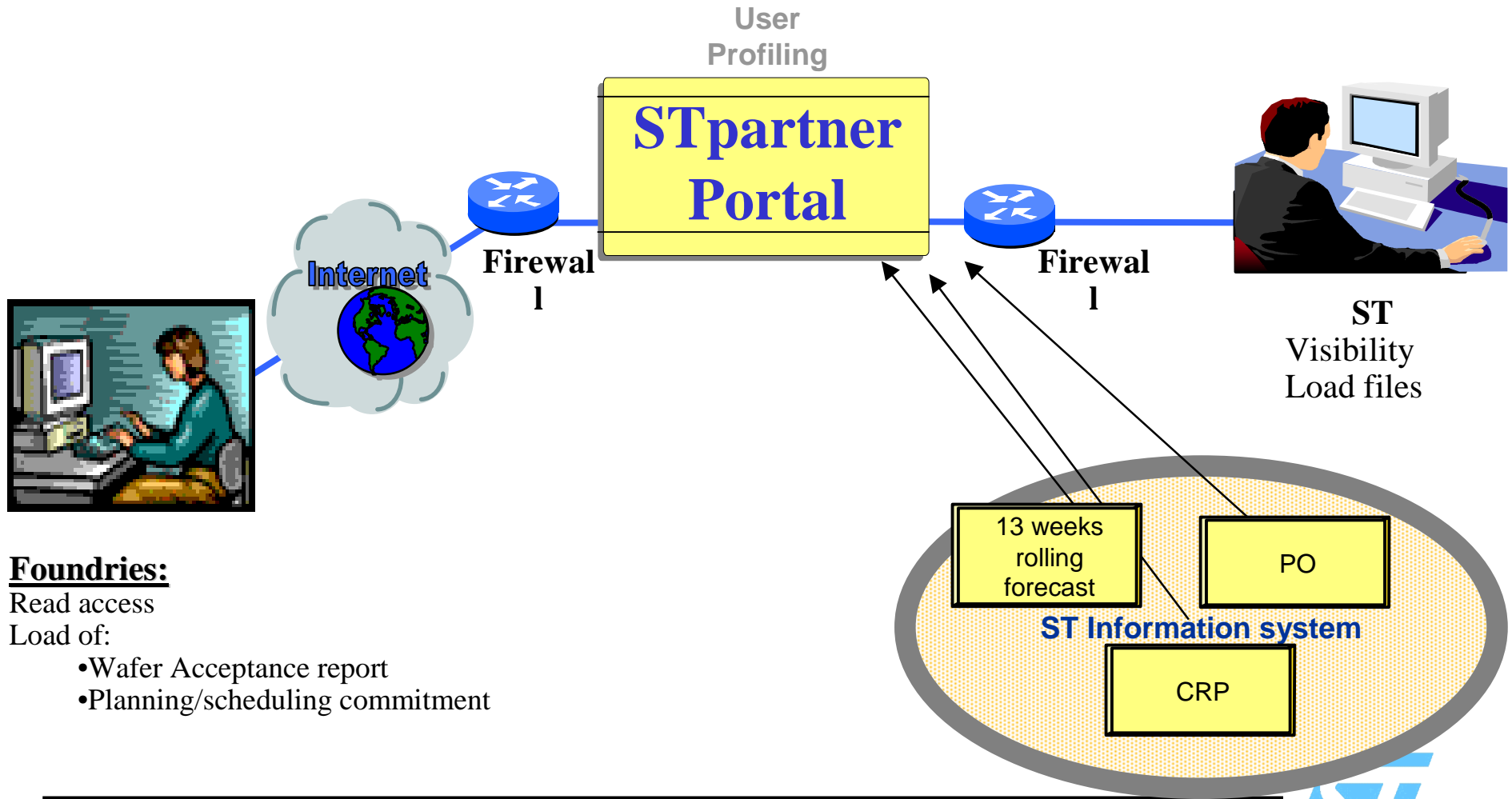

Foundries:

Read access

Load of:

- Wafer Acceptance report
- Planning/scheduling commitment

