

# ***Overview of High Efficiency EUV Source Generated by Laser-Produced-Plasma***



I.C.E. Turcu, H. Rieger, A. Stone, J.H. Morris  
*JMAR Technologies Inc., San Diego, CA*

M.C. Richardson, C. Keyser, K. Takenoshita, Chiew-seng Koay  
*CREOL, University of Central Florida, Orlando, FL*

***EUVL Source Workshop***  
February 23<sup>rd</sup>, 2003, Santa Clara, CA

# LPP EUV Source Concept

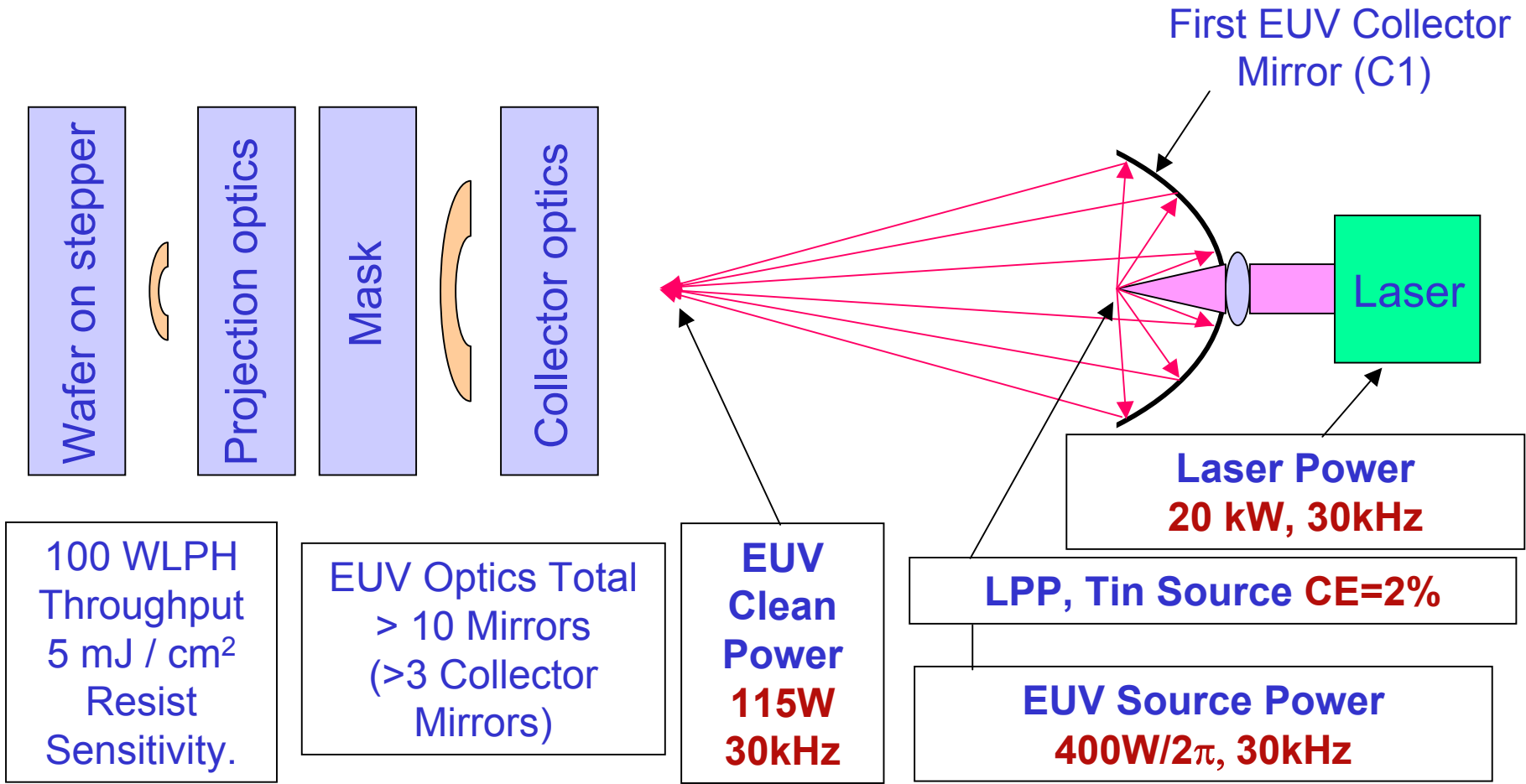

---

JMAR is developing both laser driver and EUV generator:

- High power CW diode pumped laser, at its Research Division in SD, CA
- High efficiency EUV generator based on two types of tin targets at:
  - Research Division in SD, CA,
  - University of Central Florida, Orlando, FL

# UCF development of high conversion efficiency sources - JMAR Contract



**UCF has developed (proprietary) Tin containing sources possessing high conversion efficiency (See Poster session) (patents pending)**

**Sn material droplet target**

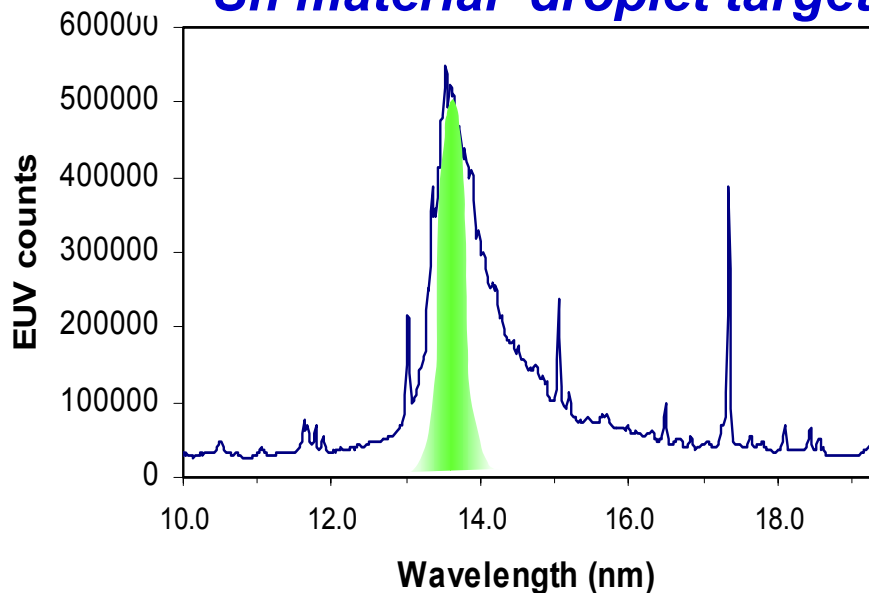

**Water droplet target**

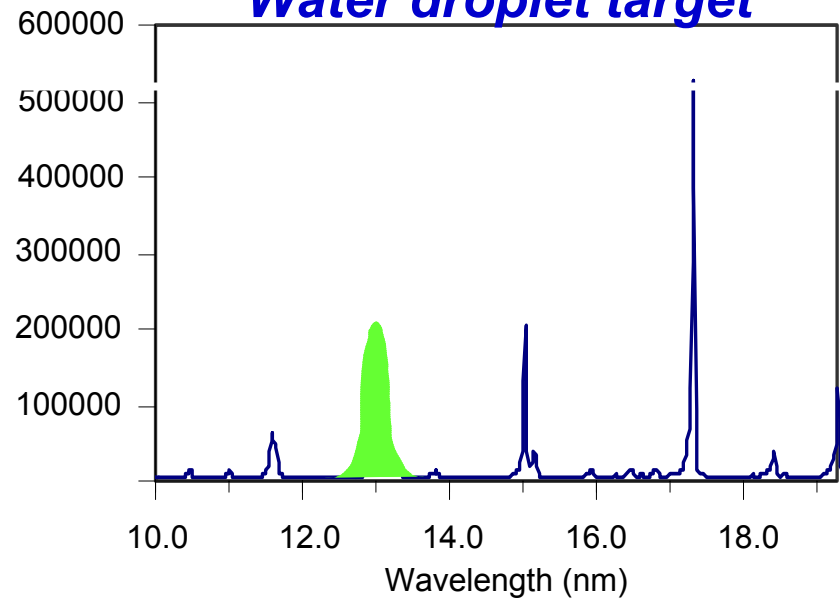

**Conversion efficiency ~ 2% at 13.6 nm into 2% BW and  $2\pi$  - based on measured CE for water of 0.315% in 2% BW and  $2\pi$**

**250 mJ, 10 ns, 1064 nm, 100 Hz laser. Spectra recorded for 150 shots**

# Initial Flying Circus measurements on conversion efficiency at CREOL

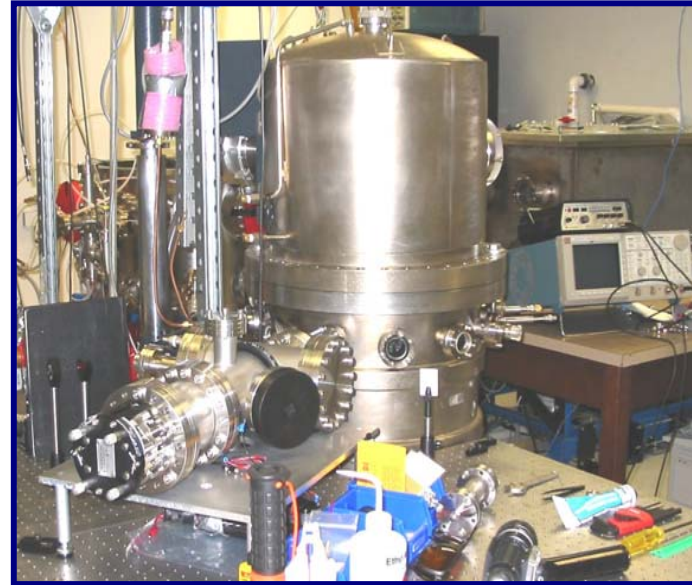
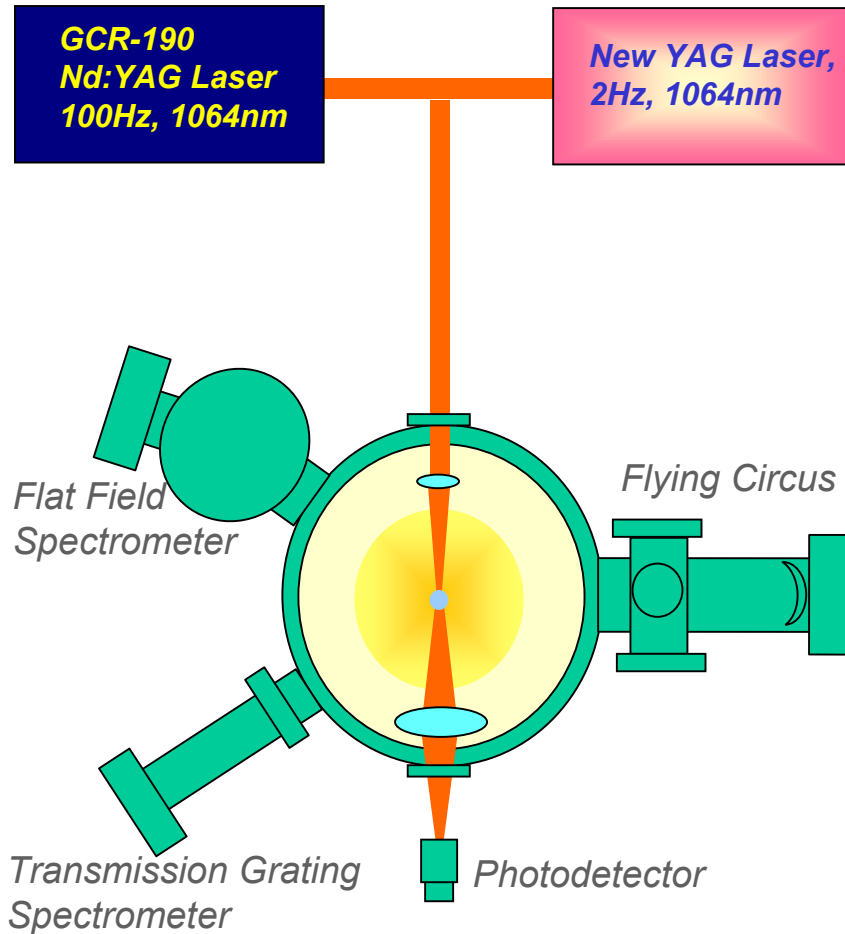

*Laser: energy 0.67J/pulse, pulse width 10ns*

*Lens: focal length 50mm, minimum spot size 20 $\mu$ m*

*Target: Droplet of Tin mixture (<10% Sn by mass), diameter 35  $\mu$ m*

*Conversion Efficiency > 1% (from Flying Circus)*

*Irradiance and target conditions not optimized*

# EUV Generator Development Facility in San Diego

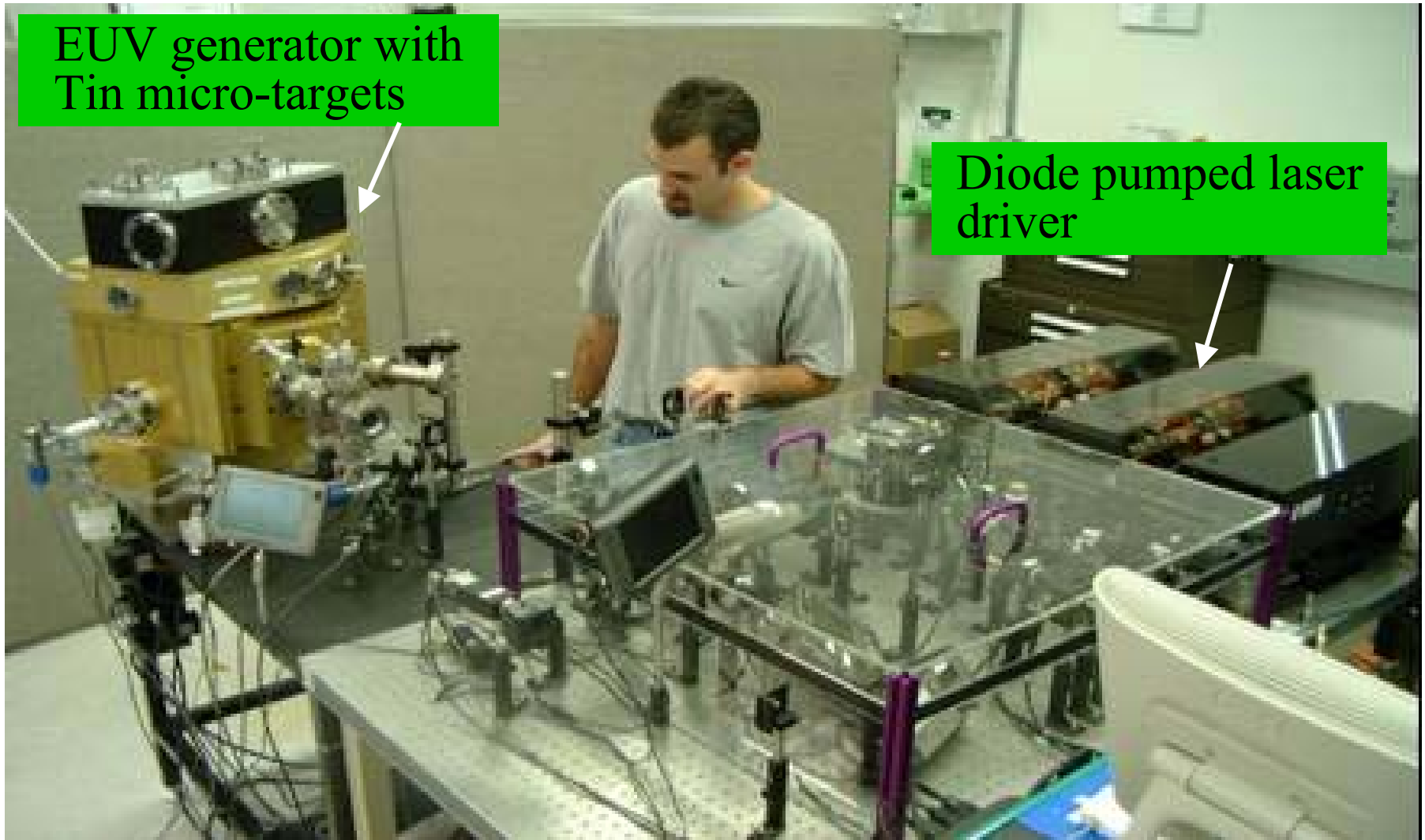

EUV generator with Tin micro-targets

Diode pumped laser driver

# EUVL Source: Generator Concept

---

- **High CE target material containing Tin**
  - $CE \geq 2\% / 2\%BW / 2\pi @ \lambda = 13.5\text{nm}$ .
- **High repetition rate: 30 kHz**
- **Debris mitigation:**
  - minimum mass targets (micro-targets)
  - buffer gas
  - gas curtain
  - E&B fields
  - differential pumping at intermediate focus.
- **Large collection angle C1 mirror:**
  - small source etendu  $\sim 0.06\text{mm}^2\text{sr}$
  - large accessible solid angle
  - stable source position

# A new repeller field configuration at CREOL

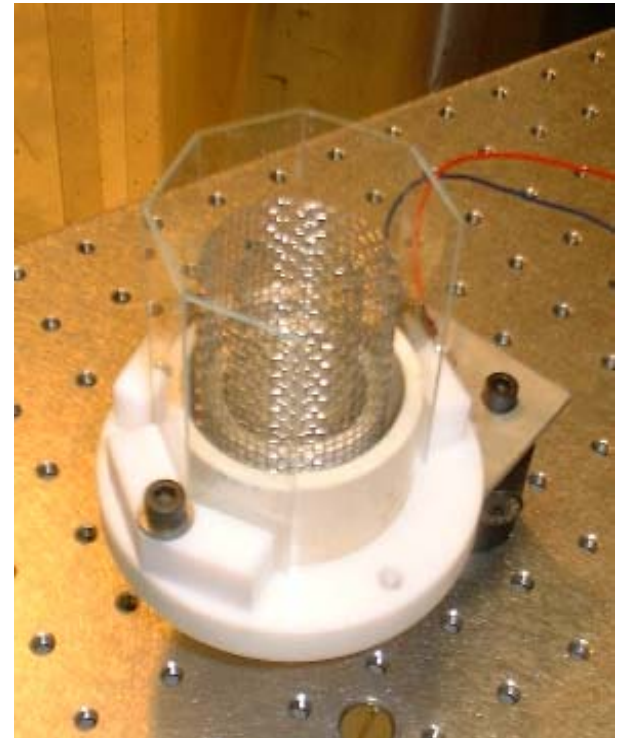
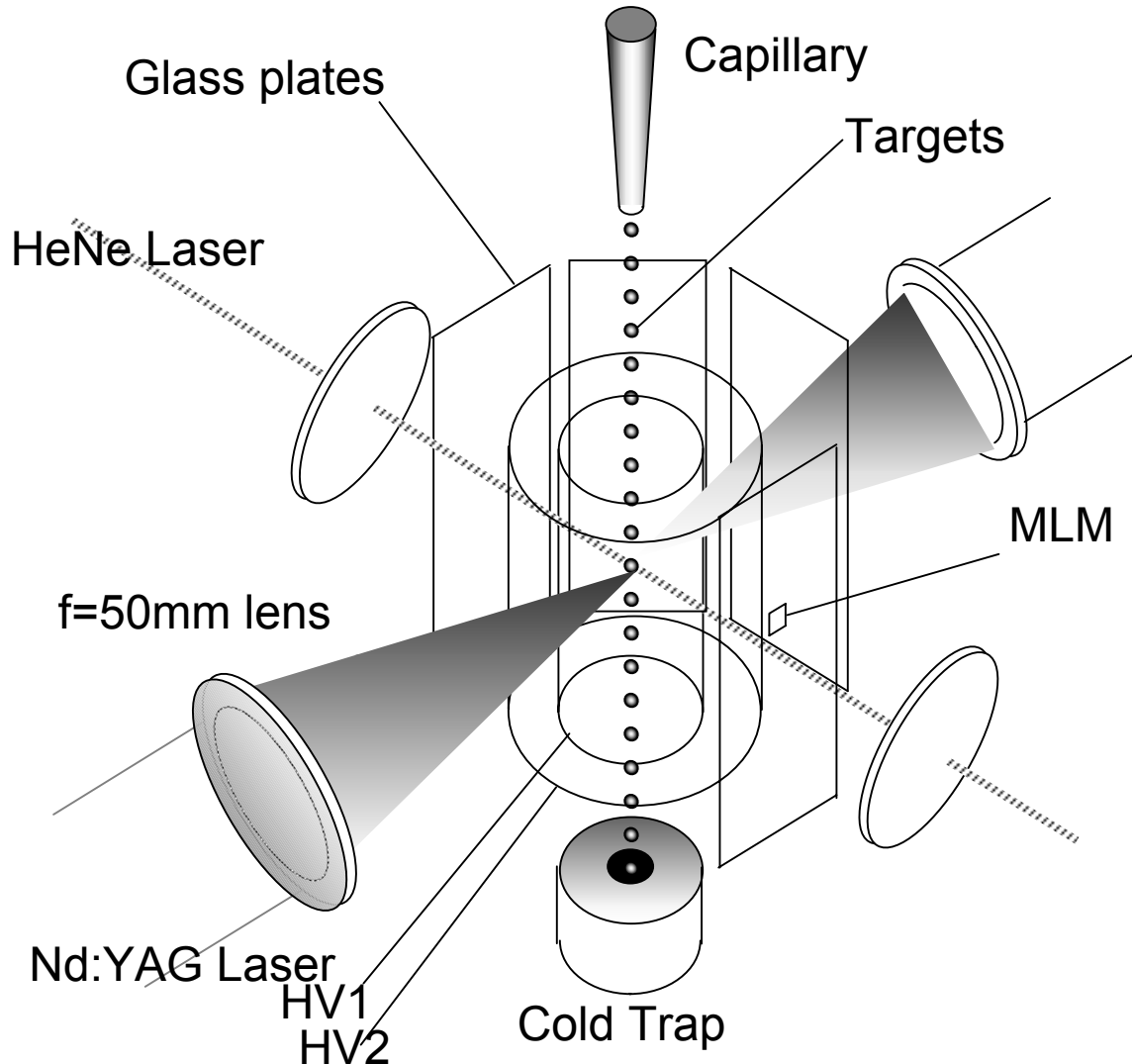

# AEM measurements with and without Repeller Field at CREOL



## *Auger Electron Microscopy Back-scattering*

*Frequency ~102 kHz*

*Image size 500  $\mu\text{m}$  x 500  $\mu\text{m}$   
30000 shots.*

*Witness plates 30 mm from target*

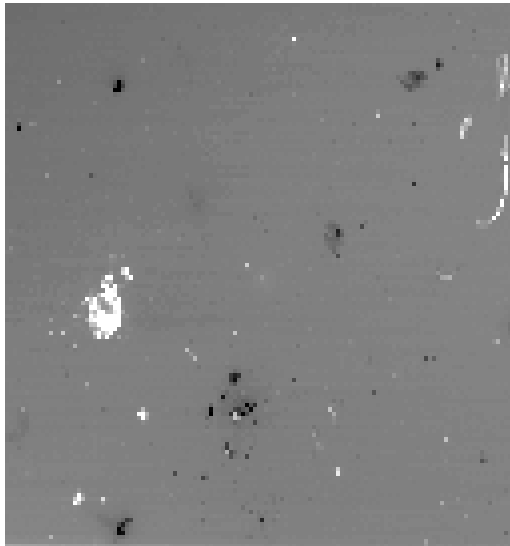

*With repeller field*

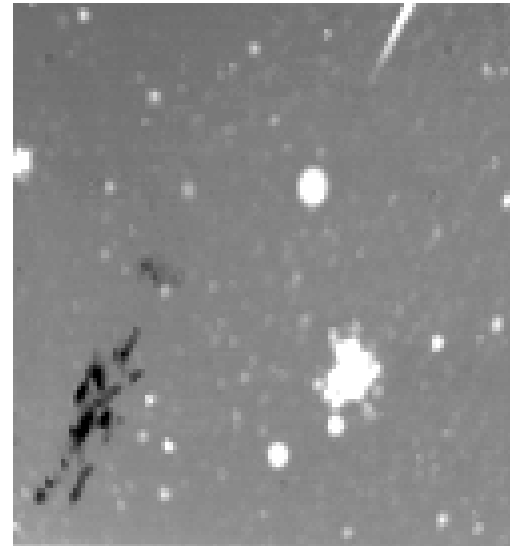

*Without repeller field*

*Less Sn deposition on MLM surface with repeller field than without the field*



# Motivation for CW Pumped Laser Development

---



- High average power needed for high throughput LPP lithography source
- Significantly lower cost in comparison to QCW pumped and other available lasers
- 30kHz repetition rate for scanning and precise dose control (EUVL requirement >10kHz)
- Strong synergy with existing JMAR's QCW laser technology
- High reliability (>20,000 hrs.)
- High thermal loading and beam power requires development
- Same development is applicable for high repetition rate QCW laser

# Nd:YAG Laser System Architecture (sample)

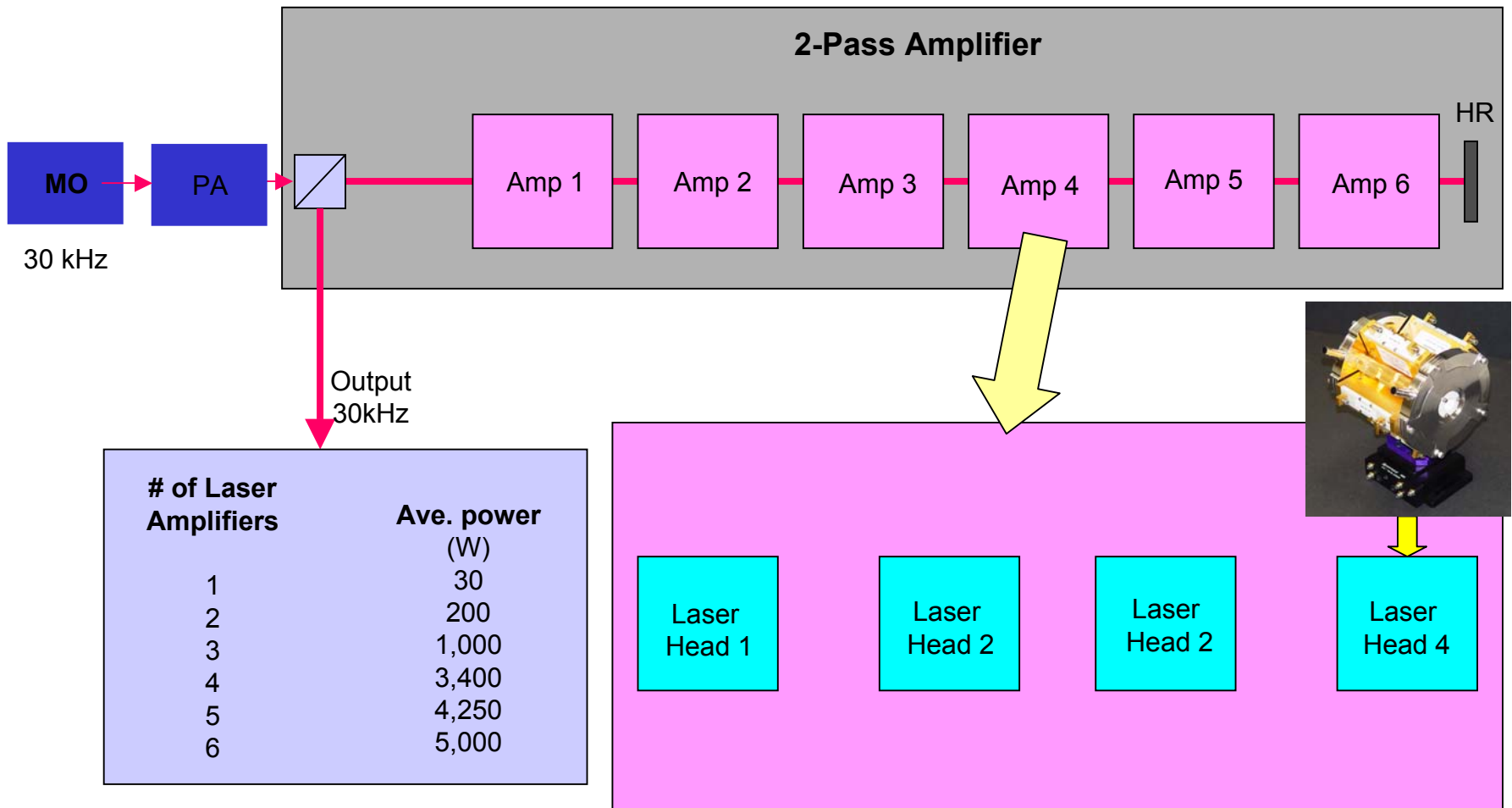

# Proof Of Concept CW Pumped Laser System (MO, PA, & 1 Amp.)



# MO Laser Beam Profiles

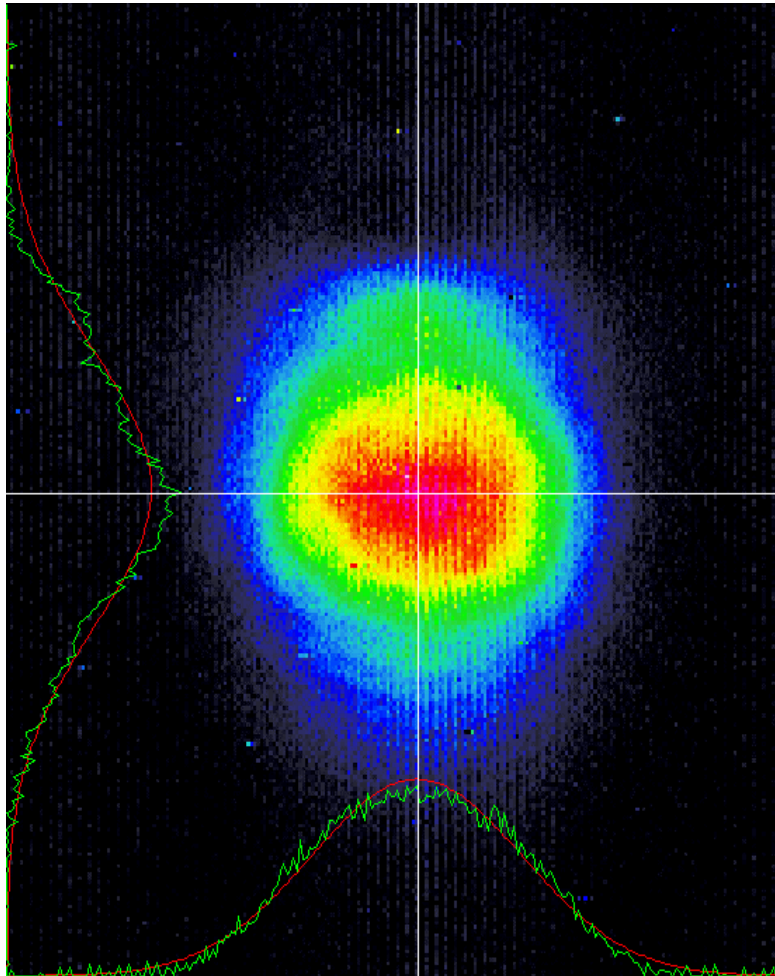

**Near Field**

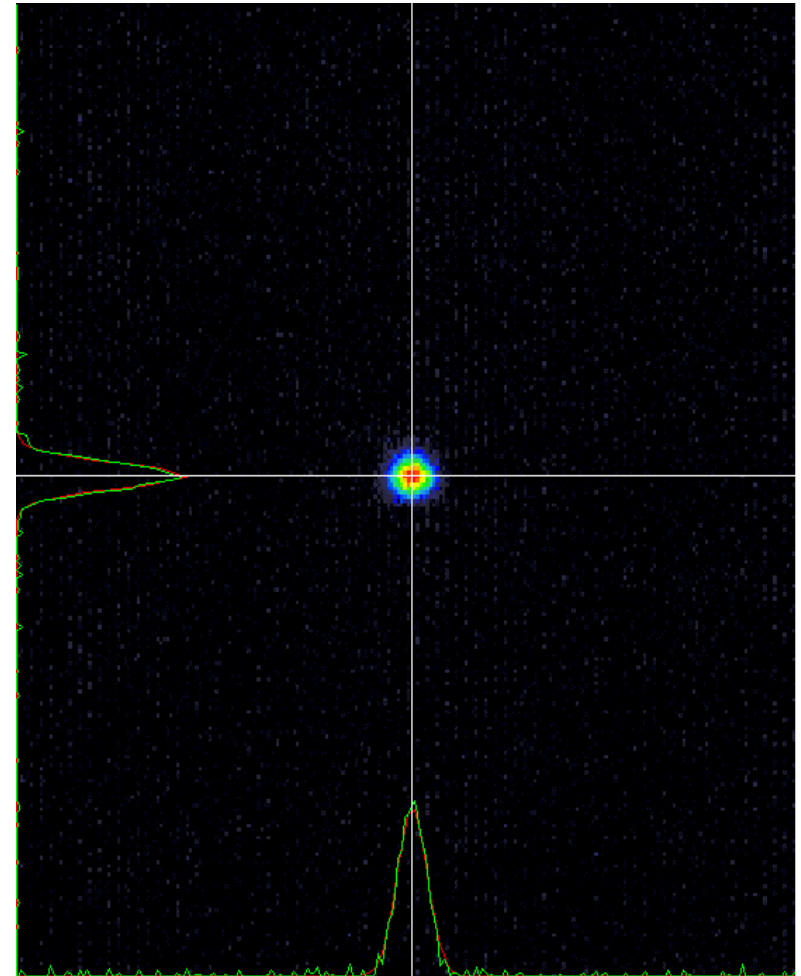

**Far Field 1xDL**

# CW Pumped Laser MO Pulse Duration



Modelocker off

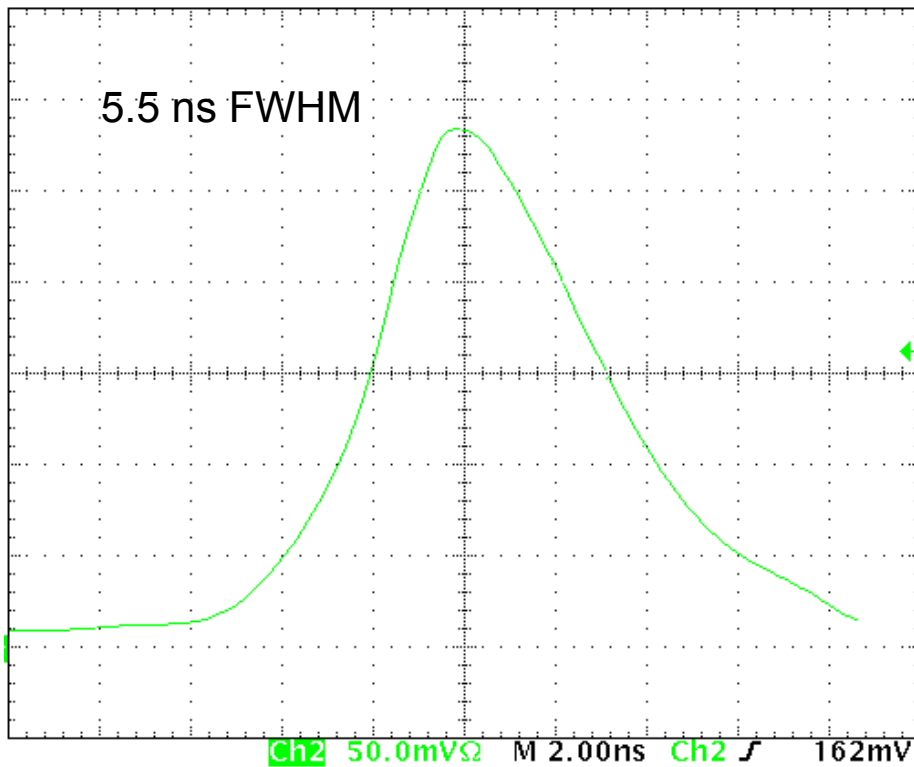

Modelocker on

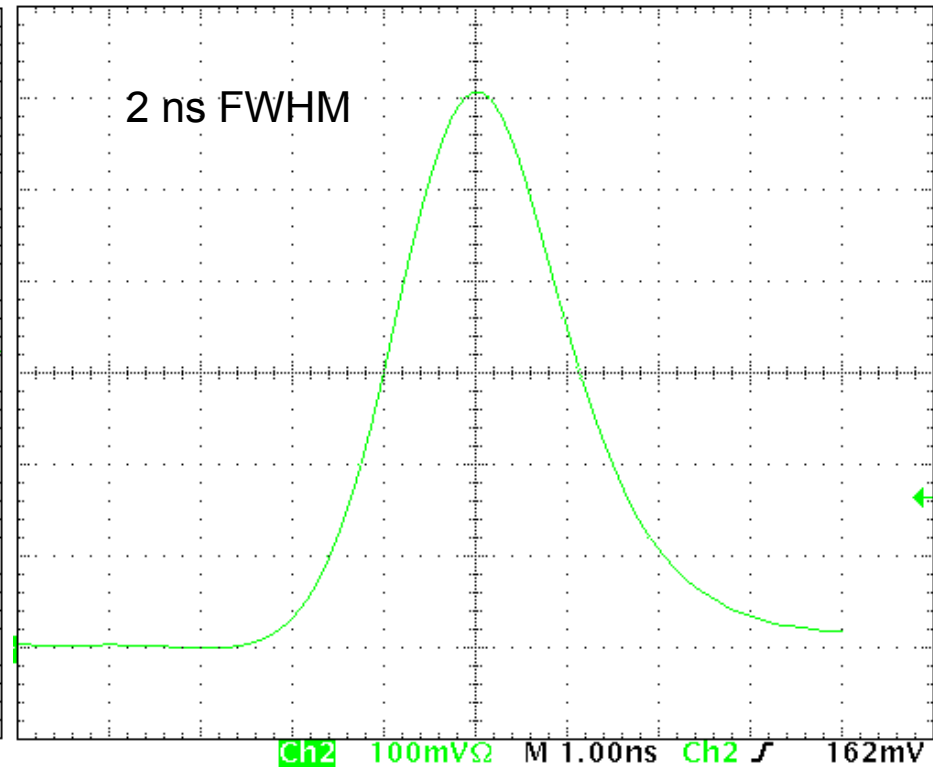

# Development Path: Laser and Generator *(If External Funding Source Procured)*



---

	Conservative	<b>Aggressive</b>
• <b>Phase I</b>		
– 200 W laser	Q4 '03	Q3 '03
– 4 W EUV Prototype	Q4 '04	Q3 '04
• <b>Phase II</b>		
– 5 kW laser	Q4 '04	Q2 '04
– 25 W clean EUV Prototype	Q4 '05	Q2 '05
• <b>Phase III</b>		
– 20kW laser	Q2 '06	Q1 '05
– 115 W clean EUV Prototype	Q2 '07	Q1 '06
• <b>Commercial EUV Source</b>		
– 25 W	Q4 '06	Q1 '06
– 115 W	Q2 '08	Q1 '07

# Supplier Report



EUV Source Performance Roadmap	External Funding Dependent							
	Mar-01	Mar-02	Sep-02	Sep-03	Mar-04	Mar-05	Mar-06	Mar-07
Central Wavelength (nm)	13.5nm	13.5nm	13.5nm	13.5nm	13.5nm	13.5nm	13.5nm	13.5nm
Demonstrated collectable EUV power in a 2% spectral bandwidth in the region between 13-14nm (W) *	0.5W/2 $\pi$	0.5W/2 $\pi$	1.6W/2 $\pi$ with TRW laser(+)	1W/2 $\pi$	4W/2 $\pi$	25W/Inter. Focus POC	115W/Int. Focus POC	115W/Int. Focus Commercial
Available collection solid angle (sr)	>2 $\pi$	>2 $\pi$	>2 $\pi$	>2 $\pi$	>2 $\pi$	>2 $\pi$	>2 $\pi$	>2 $\pi$
Source emission area (mm <sup>2</sup> )	0.01	0.01	0.01	0.01	0.01	0.01	0.01	0.01
Etendue (mm <sup>2</sup> sr)	0.06	0.06	0.06	0.06	0.06	0.06	0.06	0.06
Demonstrated maximum repetition rate (kHz)	0.3	0.3	0.5-2.5+	0.3	30	30	30	30
Demonstrated steady state repetition rate (kHz)	0.3	0.3	0.5-2.5+	0.3	30	30	30	30
Dissipated total power in source region (at steady state) (kW)	0.03	0.03	0.3-0.6+	0.05	0.2	5	20	20
Source-facing condenser lifetime (# of pulses to 10% reflectance loss)	2E8**	2E8**	>E6 estimate	2.00E+08	2.00E+09	2.00E+10	2.00E+11	2.00E+11
Pulse to pulse spatial stability ( $\mu$ m 3s)	~20 $\mu$ m	~20 $\mu$ m	~20 $\mu$ m	~20 $\mu$ m	~20 $\mu$ m	~20 $\mu$ m	~20 $\mu$ m	~20 $\mu$ m
Pulse to pulse intensity stability (3s)	~50%	~50%	~50%	10%	5%	2%	<2%	<2%
Pulse to pulse angular stability (3s)	uniform	uniform	uniform	uniform	uniform	uniform	uniform	uniform
Pulse to pulse pointing stability (3s)	uniform	uniform	uniform	uniform	uniform	uniform	uniform	uniform
Key risk areas	Debris	Debris	Debris	Debris	Debris	Debris	Debris	Debris
Critical component lifetime	C1mirror	C1mirror	C1mirror	C1mirror	C1mirror	C1mirror	C1mirror	C1mirror

\* No filters, \*\* Similar target. (+) Joint TRW/CEO and JMAR experiment

# Activities for Development

---



- Top 3 issues for LPP technology development
  - Issue 1: Debris mitigation for 2year life of C1
  - Issue 2: Conversion efficiency of  $\geq 2\%$  2p/  
2%BW@13.5nm from low debris targets
  - Issue 3:  $\geq 5$  kW CW DPSS laser development
- Topics for Pre-competitive research/development
  - Topic 1: Debris/heat mitigation
  - Topic 2: C1 mirror (geometry/collection angle).
  - Topic 3: Metrology standard.