Is it too early to make a decision between GDPP and LPP?

Martin Richardson
*Laser Plasma Laboratory,
School of Optics/CREOL,
UCF, Orlando, FL 32732,
email:mcr@creol.ucf.edu*

Why it Is too early to make a decision between GDPP and LPP

Martin Richardson
*Laser Plasma Laboratory,
School of Optics/CREOL,
UCF, Orlando, FL 32732,
email:mcr@creol.ucf.edu*

Why are we asking this question?

Maintaining two development paths is too expensive

Two industrial withdrawals from LPP in 2003

Q1 2003

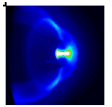

10

20

30

40

50

60

70

80

90

100



CEO ~20 W, 2π
Q1 2003
4 kW



130 W, 2π
2004
CE=1.1, 12kW

260 W, 2π
2004
CE=2.2, 12kW



Progress in 2003

Q1 2004

Cymer
76W 2π
CE= 0.5

PE
126W 2π
CE= 0.5

ET
150W 2π
CE= 0.5

Q1 2003

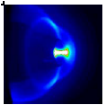

Q4 2003

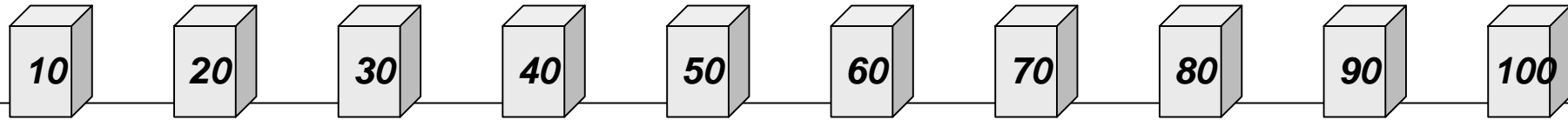

EX
8W 2π
CE= 0.8

ET
2004
CE=1.1, 12kW

PL
8W 2π
CE= 0.8

130 W, 2π
2004
CE=1.1, 12kW

260 W, 2π
2004
CE=2.2, 12kW



MOPA or Multiplexed Laser Module approaches

MASTER OSCILLATOR – POWER AMPLIFIER

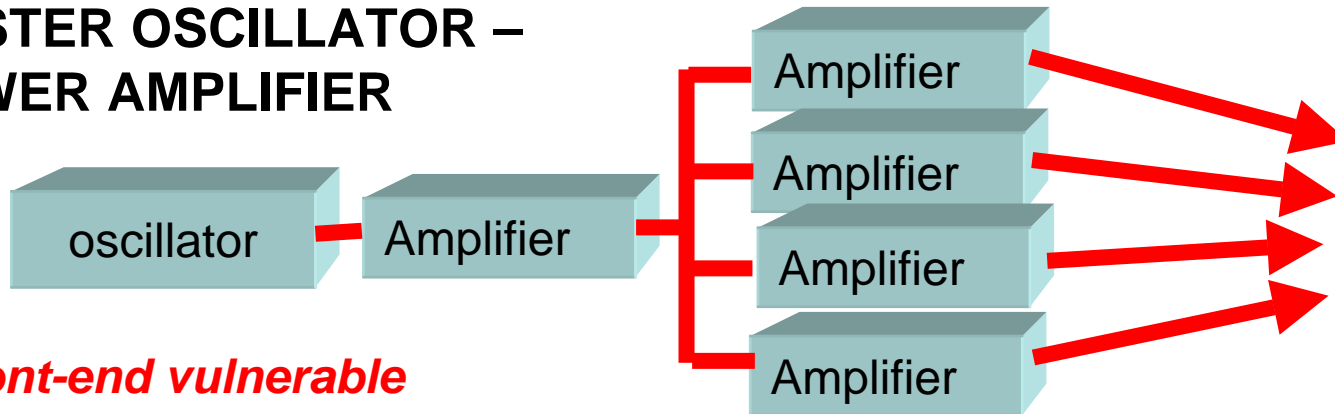

front-end vulnerable

MULTIPLYED LASER MODULE

- *Redundancy.*
- *Temporal and Spatial Multiplexing.*
- *Higher RR and dose control*
- *Less technical stress*
- *Cost reductions*

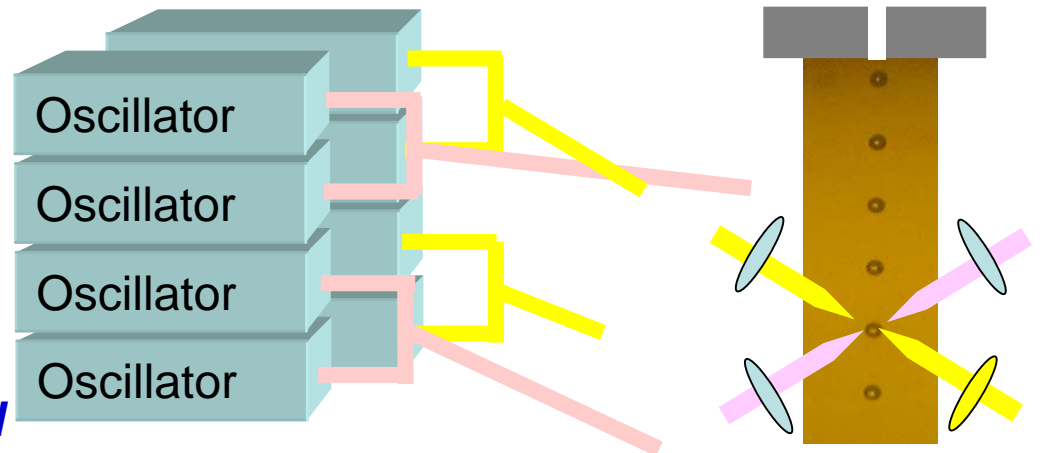

**100 kHz
source supply**

Laser developments (1)

- Modular & adaptative concept
 - 10 high-power, diode-pumped 500 W laser oscillators combined to obtain a 5 kW laser system.

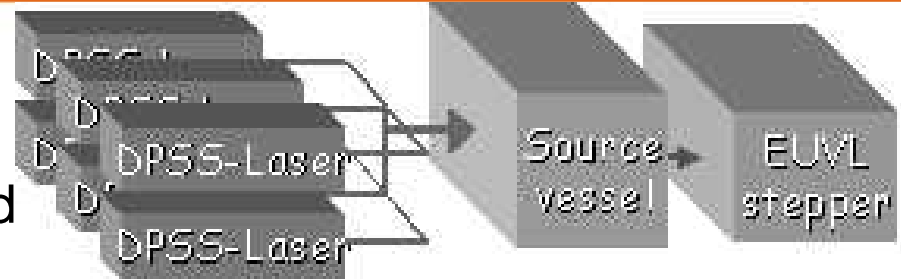

- Development of small, reliable, & affordable power oscillator units (instead of a **MOPA**)
 - Diode-pumped solid-state-lasers
 - Simple
 - Compact size
 - Highly efficient
 - High Reliability



Conversion and collector efficiency is crucial

A 1% CE implies a 20 kW laser for 100 W at IF

**Moving from
Xe to Sn**

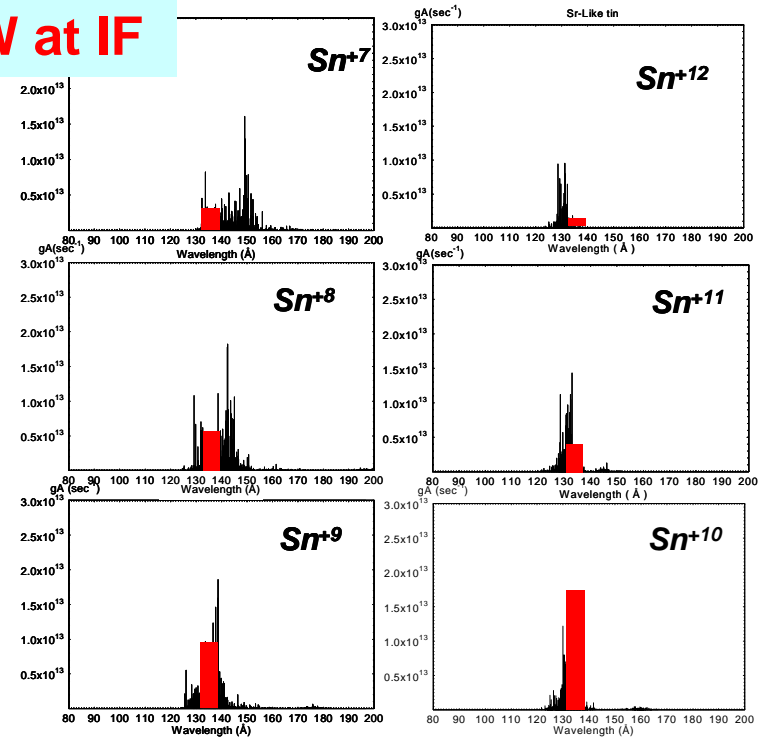
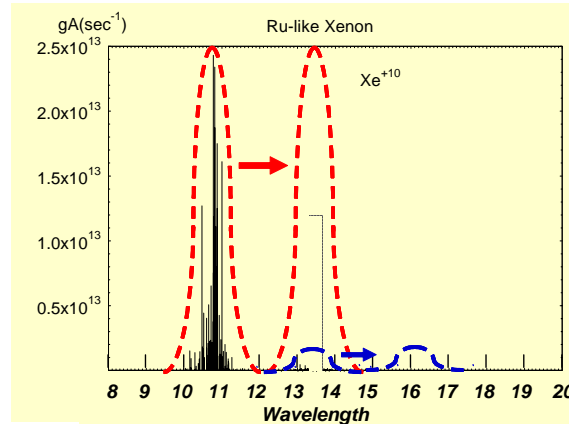

**CE's (now) of 1.3% (mass-limited)
2 -3% (solid)**

Higher collection efficiencies

Open access laser plasma may allow more than 2π ?

The debris and erosion problem

MULTIPLICITY OF MITIGATION SCHEMES

(Foil trap, Repeller Field, B-Fields, Gas Curtain)

TIN MITIGATION MAY NOT BE SO DIFFICULT

Repeller fields stop particles as well as ions

*Silicon witness plates. 3×10^4
Auger electron elemental map (Sn signal only)*

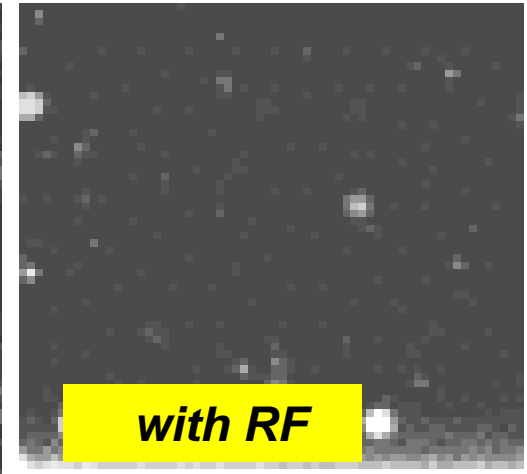
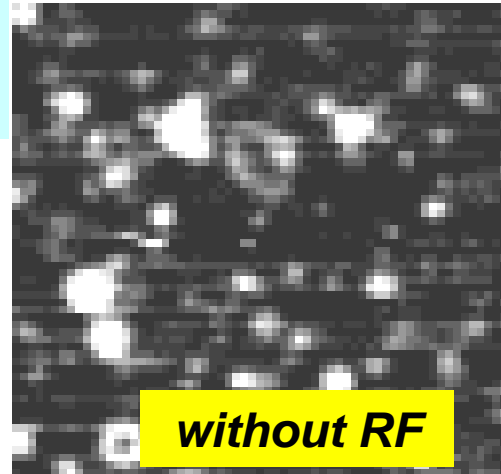

REPLACABLE COLLECTORS

**Low cost replaceable kinoform or solid first mirror reflectors
....reductions of mirror lifetimes to $\sim 10^{10}$**

Breakout Session Discussion

- 1. Is it the time to choose now?**
- 2. What benefits do we gain from making a decision now?**
- 3. If we are to make a decision, then when?**
- 4. What obstacles should we anticipate at higher powers?**
- 5. What issues, effects need greater emphasis? (beyond CE and debris)?**
- 6. Are there any organizational changes that we need to make in order to move faster?**

Breakout Session Discussion

- 1. Is it the time to choose now?**
- 2. What benefits do we gain from making a decision now?**
- 3. If we are to make a decision, then when?**

Breakout Session Discussion

1. Is it the time to choose now?
2. What benefits do we gain from making a decision now?
3. If we are to make a decision, then when?
- 4. What obstacles should we anticipate at higher powers?**
- 5. What issues, effects need greater emphasis? (beyond CE and debris)**
- 6. Are there any organizational changes that we need to make in order to move faster?**