

# Effects of High Moisture on the Purification of Clean Compressed Air

Joe Rotter, Allan Tram, & Jeffrey J. Spiegelman

**Mykrolis Corporation**

Gas Microcontamination Business Unit  
6975 Flanders Drive, San Diego, CA 92121

# Purpose

- Determine siloxane removal efficiency for three purification medias from clean dry air (CDA)
  - > Activated Carbon
  - > Base-activated Carbon
  - > Proprietary Inorganic Media (PIM)
- Examine the ability of the three medias to remove siloxane under presence of high moisture (30% relative humidity)
- Investigate the removal efficiency of the medias after being “regenerated”

# What are AMCs?

- Airborne Molecular Contaminants (AMCs)
  - > Condensable and Non-condensable hydrocarbons
  - > Inorganic acids and bases
  - > Siloxanes
  - > Refractory compounds that contain N, S, or P
  - > H<sub>2</sub>O
- Effects of AMCs
  - > Optics contamination and hazing
  - > Poisoning of photoresists
  - > Degradation of gate oxide integrity due to organic contamination
  - > Device degradation due to acid gas corrosion
  - > Poor device performance due to unwanted doping
  - > Loss of process control (e.g., etch rates)

# Sources for Contamination in Cleanrooms

- Process tools, their chemicals and by-products
- Outside air
- Cleanroom materials
- Wafers

# Current Technology used for Cleanroom AMC Prevention

- Tool based chemical filters
  - > Recirculate air inside tool
  - > Remove AMCs
- Cleanroom based chemical filtration systems
  - > Carbon HEPA<sup>®</sup> filters
  - > Recirculate room air
  - > Remove AMCs

# Chemical Filters

- **Operating Conditions**

- > Operates at 30-80% R.H.
- > Removes siloxanes,  $\text{SO}_x$  and organics (HMDS & other AMCs)
- > Binding site competition between AMCs
  - Reports from the field show premature breakthrough of cleanroom filters for siloxanes
  - Siloxanes cause permanent  $\text{SiO}_2$  and graphite build-up on optical lenses

- **Drawbacks**

- > End-of-life uncertainty
- > Contamination nonspecificity
- > Maintenance
  - Scheduled
  - Unscheduled

# Experimental

- Purification Technology:
  - > Activated Carbon
  - > Base-activated Carbon
  - > Proprietary Inorganic Media (PIM)
- Efficiency Test
  - > Test 1: Compare purification technology under dry UHP grade CDA (<100ppb H<sub>2</sub>O)
  - > Test 1A: Compare purification technology under wet gas (30% relative humidity)
- Regeneration Test
  - > Determine efficiency after regeneration

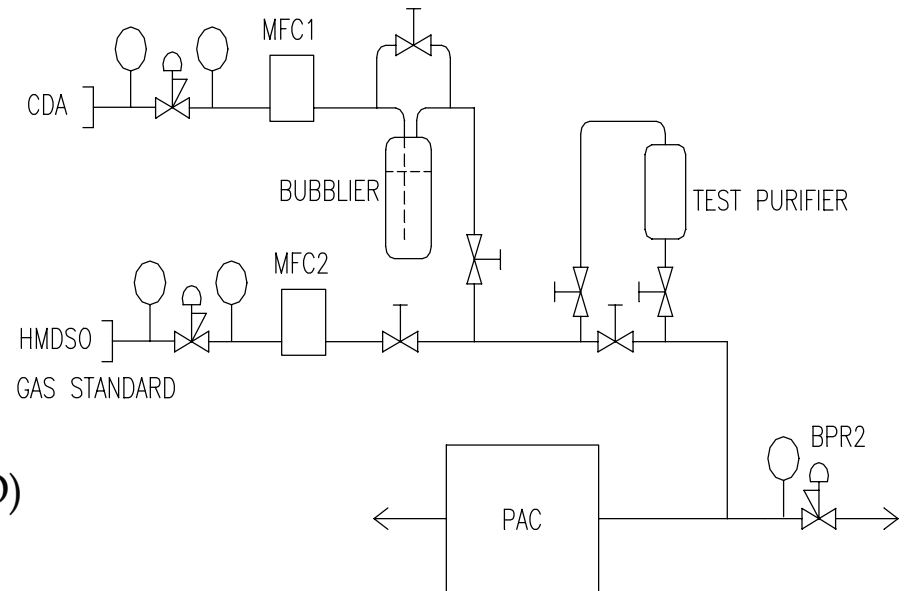

# Analytical Tool – Aeronex<sup>®</sup> PAC<sup>™</sup>



## Aeronex PAC Gas Chromatograph w/ Cold Trap

- >FID: <1ppt LDL organic
- >PFPD: <1ppt LDL S, N, P-containing compounds
- >1ppt signal generation

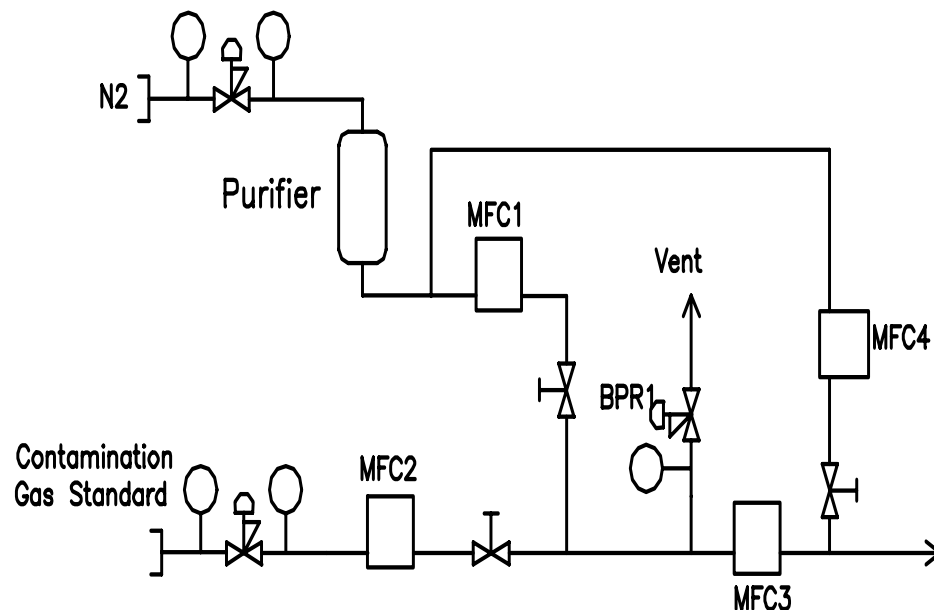

## Double Dilution Manifold

# Calibration Curve for HMDSO

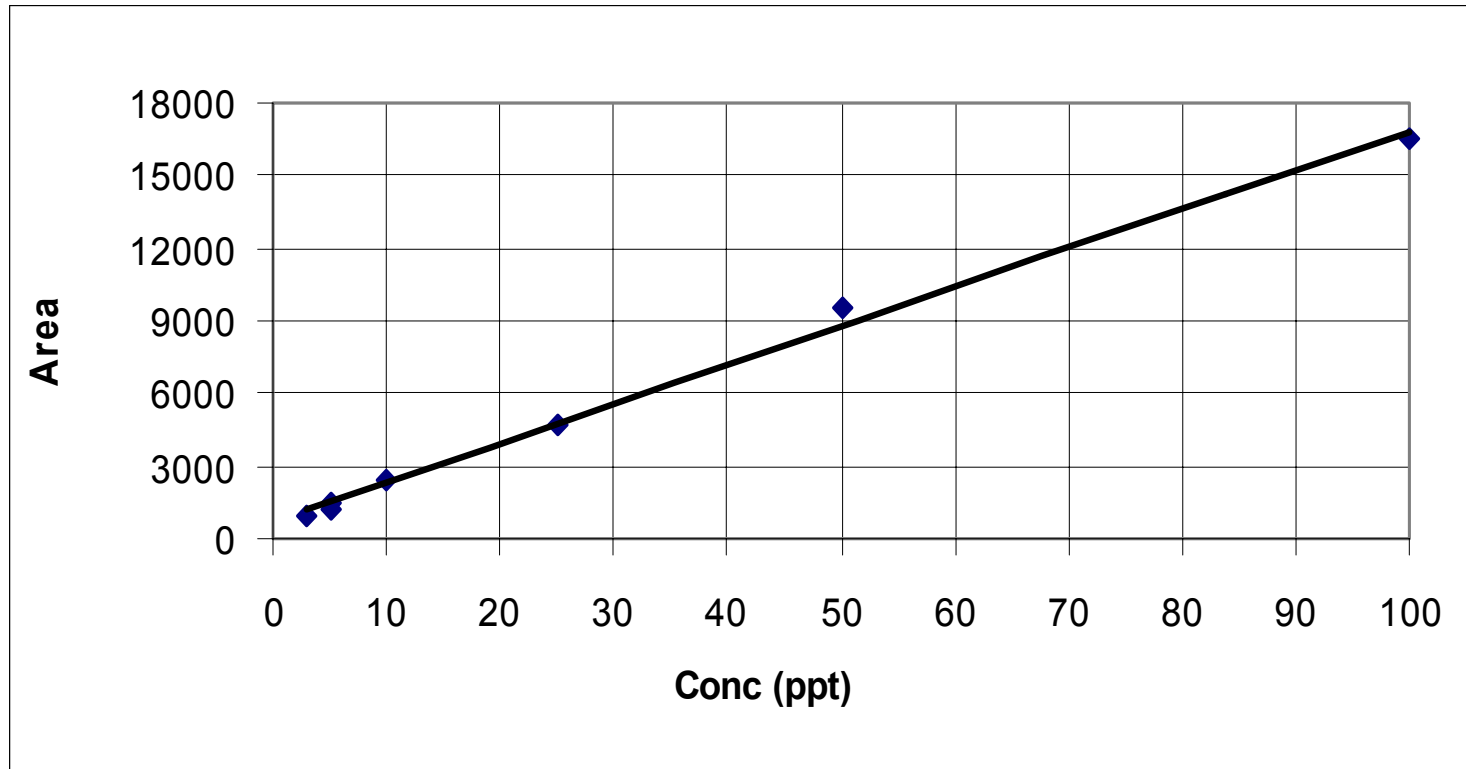

Detector: FID

LDL: 1ppt

$R^2 = 0.9951$

# HMDSO Removal Efficiency Test

Chemical Formula  $(\text{CH}_3)_3\text{-Si-O-Si-(CH}_3)_3$

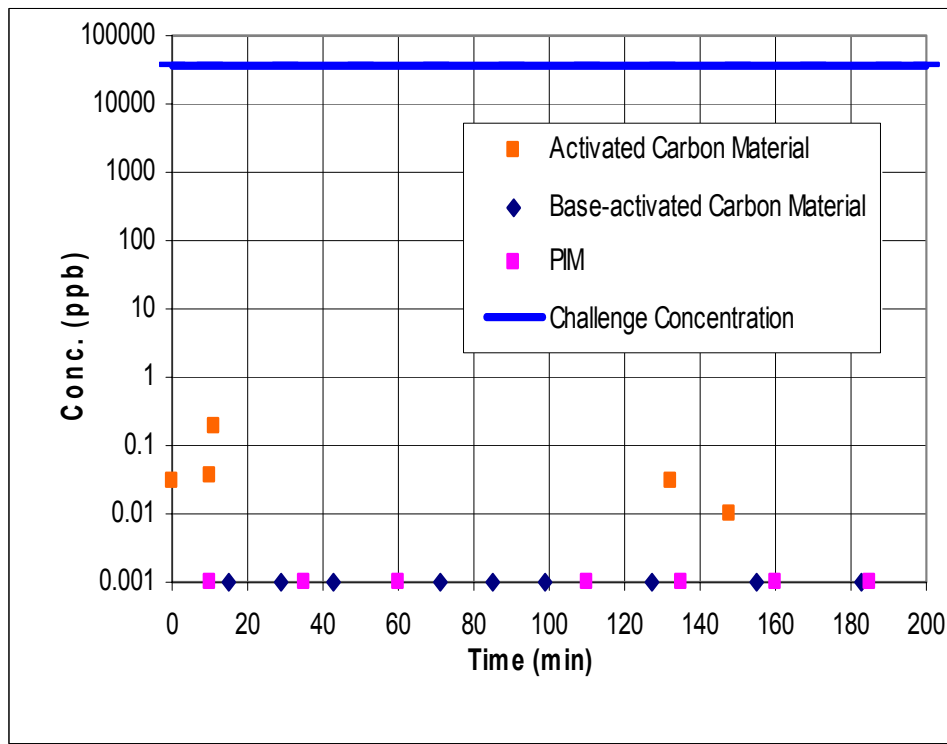
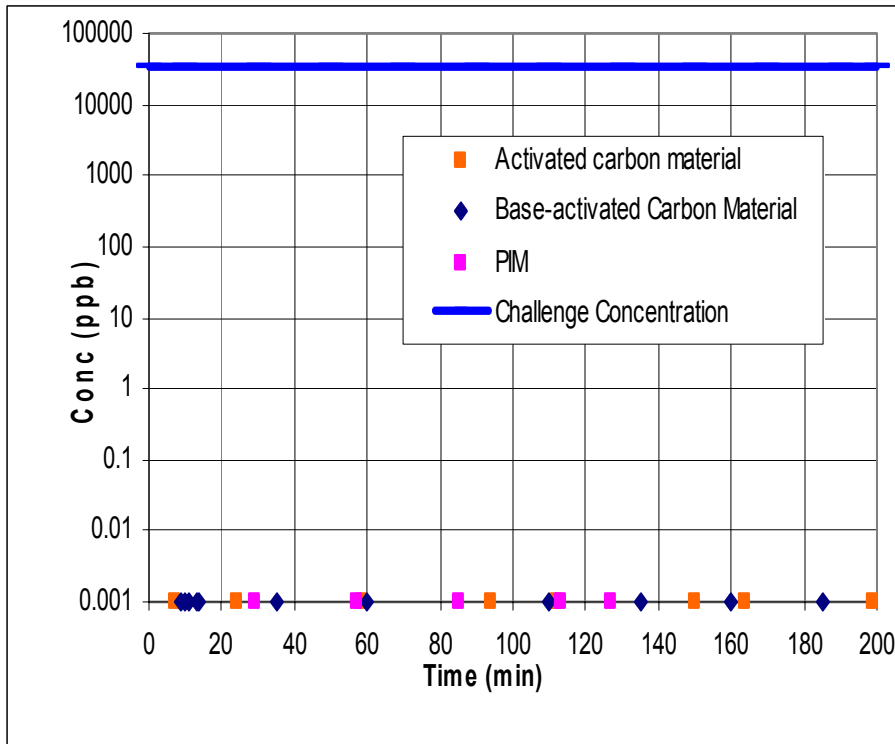

Challenge: 65 ppm HMDSO  
 Inlet balance gas: UHP grade CDA (<100ppb H<sub>2</sub>O)  
 Outlet: <1ppt hydrocarbon  
 Detector: FID  
 LDL: 1ppt

Challenge: 35 ppm HMDSO  
 Inlet balance gas: UHP grade clean air (30% R.H.)  
 Outlet: <1ppt hydrocarbon (except Act. Carbon <500ppt)  
 Detector: FID  
 LDL: 1ppt

# Benefits of Regenerable Media

- Regeneration minimizes purifier performance uncertainty
- Process can be automated
  - > Elimination of manual labor
  - > Limited maintenance

# Regeneration Cycle

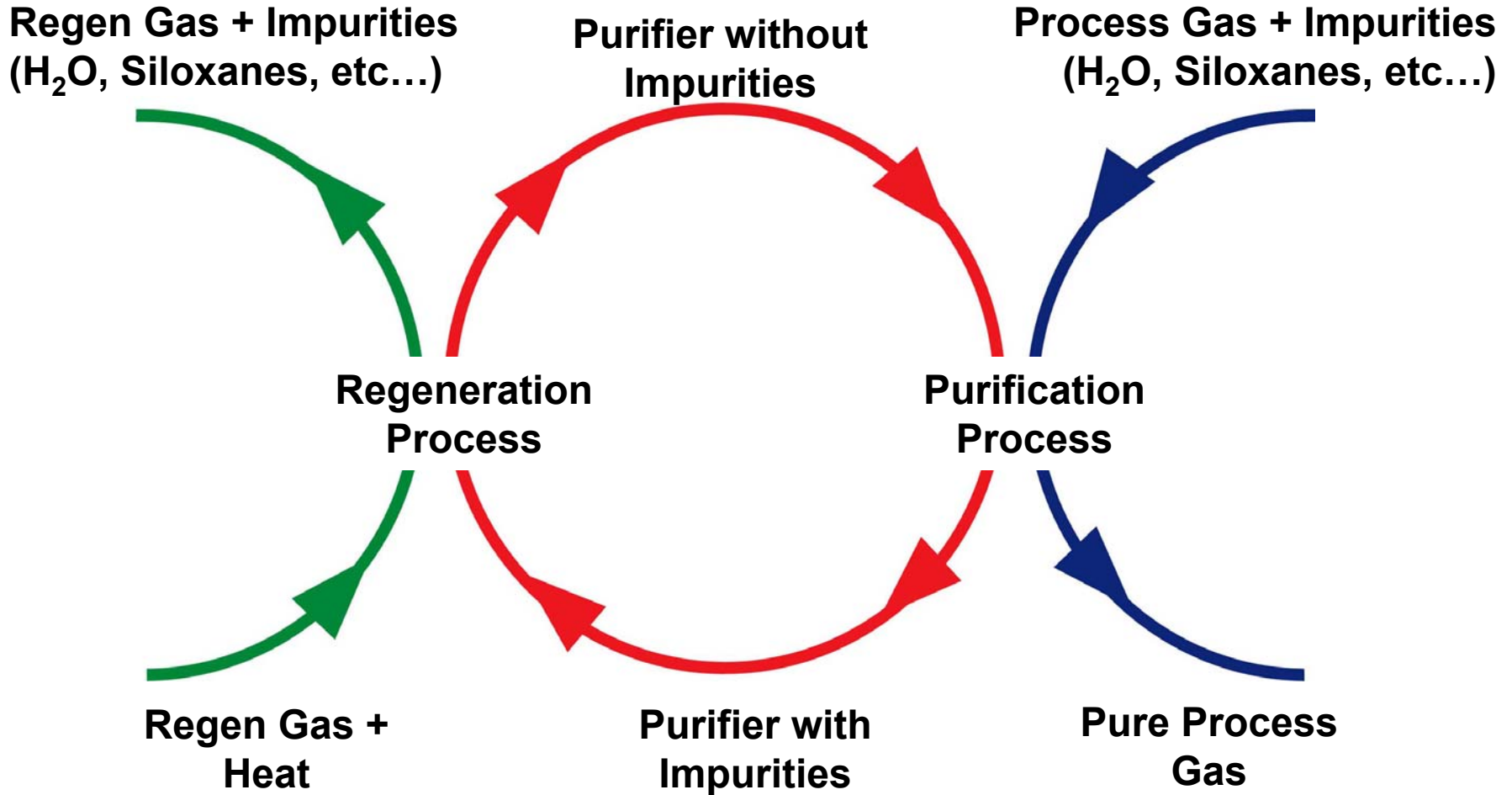

# Regeneration Results for Activated Carbon Material

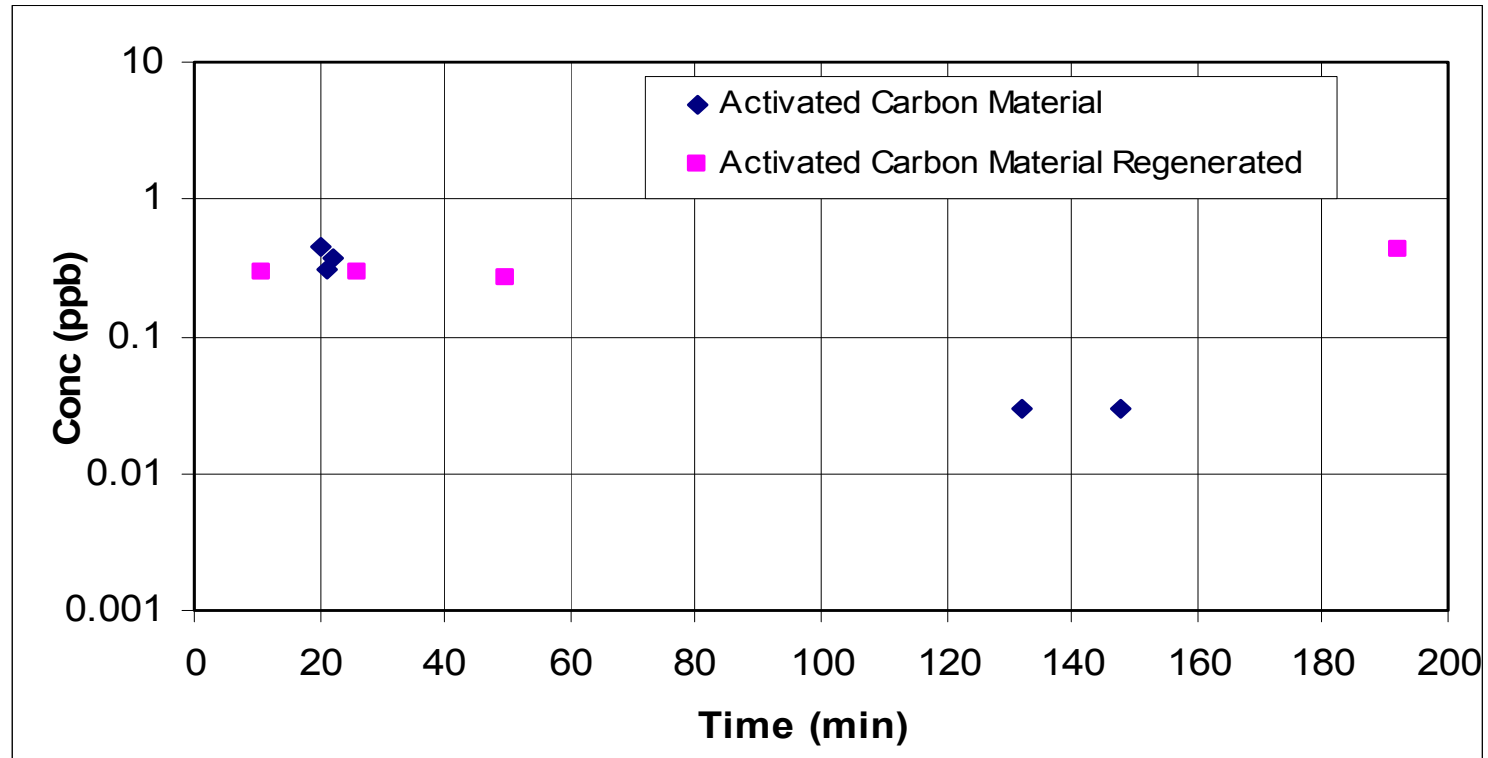

Challenge: 35 ppm HMDSO

Inlet balance gas: UHP grade CDA with 30% relative humidity

Outlet: < 500ppt of hydrocarbons

Detector: FID

LDL: 1ppt

# Regeneration Results for Base-activated Carbon Material

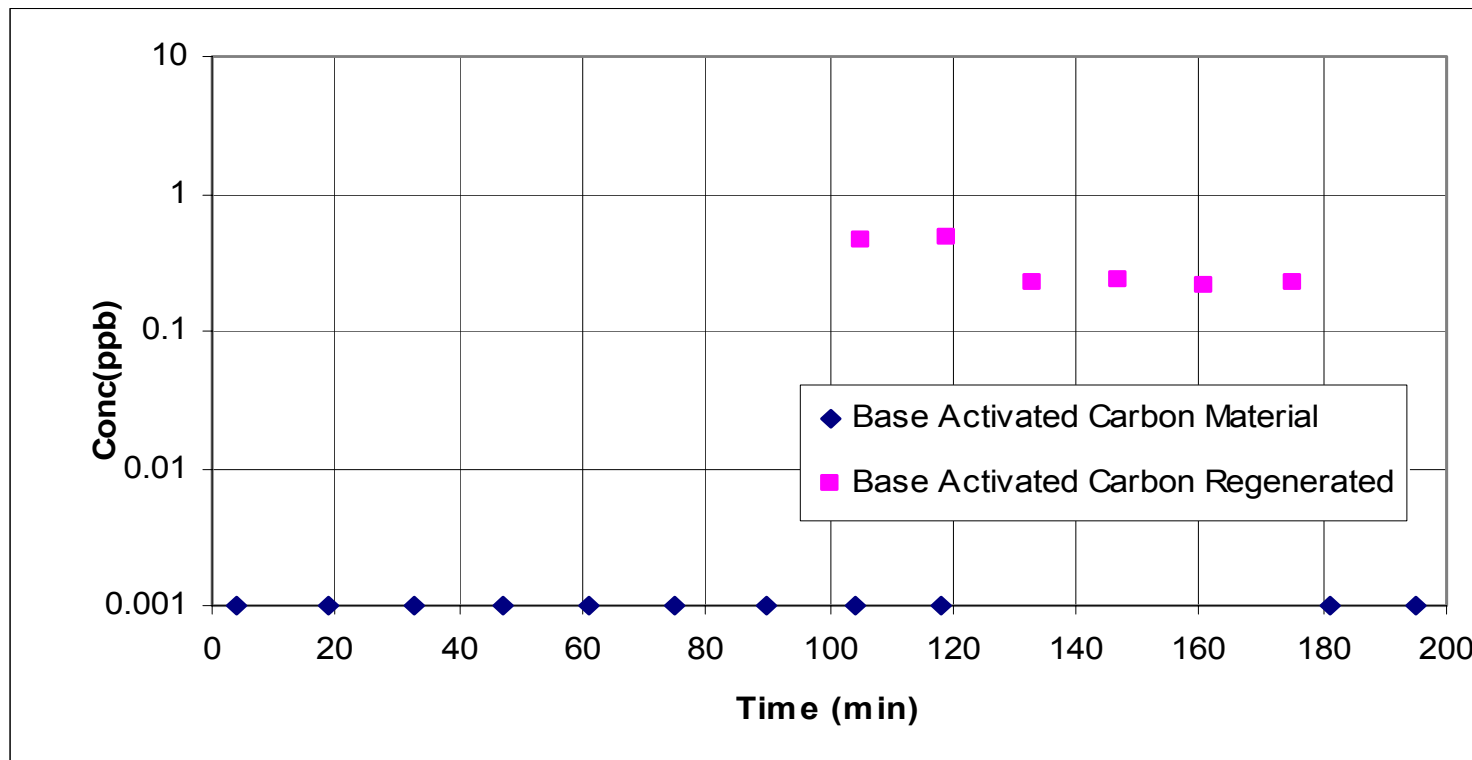

Challenge: 35 ppm HMDSO

Inlet balance gas:UHP grade CDA with 30% relative humidity

Outlet: < 600ppt of hydrocarbons

Detector: FID

LDL: 1ppt

# Regeneration Results for PIM

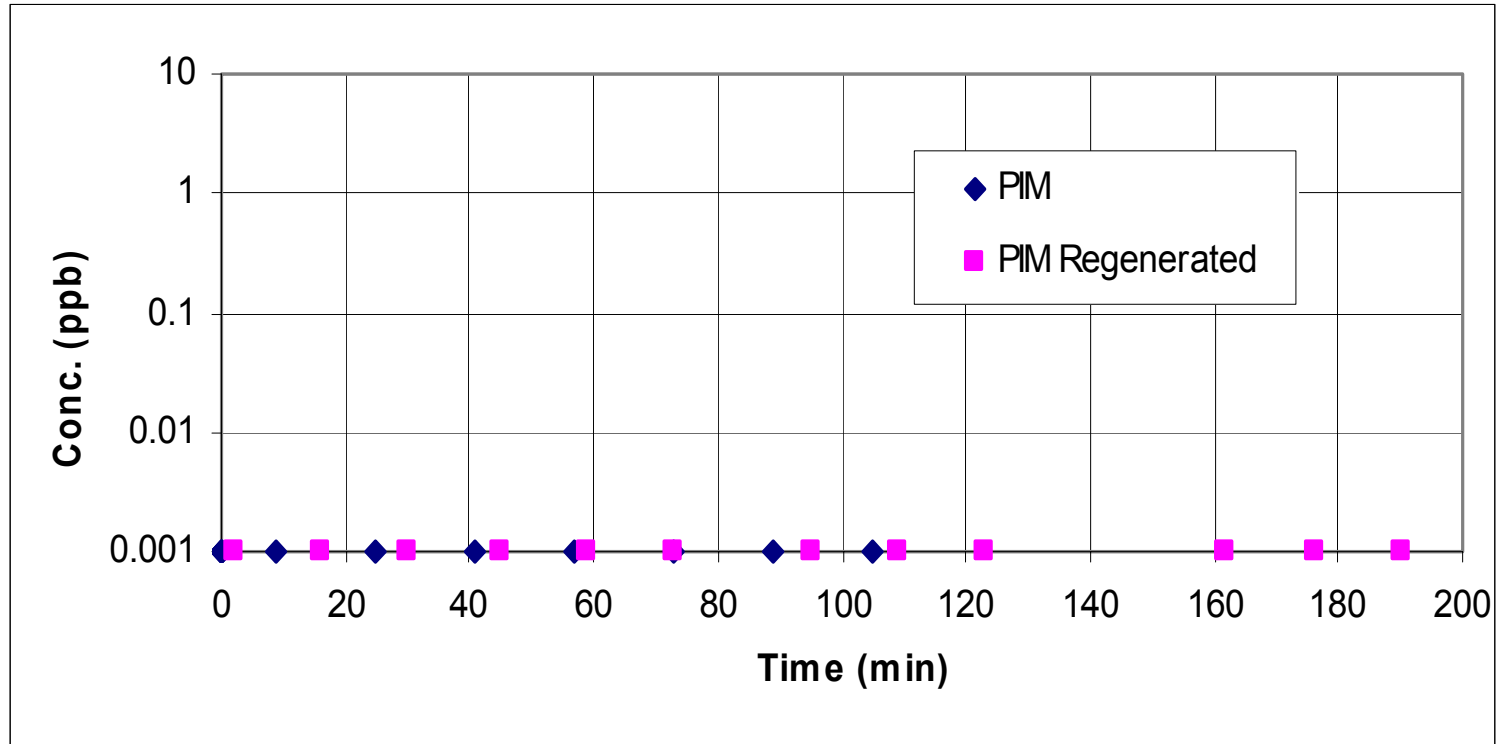

Challenge: 35 ppm HMDSO

Inlet balance gas: UHP grade CDA with 30% relative humidity

Outlet: < 1ppt of hydrocarbons

Detector: FID

LDL: 1ppt

# HMDSO Removal Results

Media	Efficiency under dry CDA	Efficiency under CDA with 30% R.H.	Regenerable (below 1ppt)
Activated Carbon	< 1 ppt	< 500 ppt	No
Base-activated Carbon	< 1 ppt	< 1 ppt	No
PIM	< 1 ppt	< 1 ppt	Yes

# Conclusions

- Limited efficiency for HMDSO removal in the presence of H<sub>2</sub>O for Activated Carbon (<500ppt)
- Base-activated carbon and PIM can remove HMDSO under high humidity condition to <1ppt
- PIM media can be regenerated for siloxane removal to below 1 ppt

## References

A. Tram, R. Holmes, J. Spiegelman, D. Alvarez, *Proc. SPIE 5075-171* (2004)



**Enabling the processes that enable the future**

*Formerly the Microelectronics Division of Millipore Corporation  
Acquisitions (2003) Aeronex; (1997) Tylan General & Span Instruments*

*Aeronex and Mykrolis are registered trademarks of Mykrolis Corporation.  
PAC is a trademark of Mykrolis Corporation.  
HEPA is a registered trademark of HEPA Corporation.  
©2001-2004 Mykrolis Corporation. All rights reserved.*